

**DESIGN AND SIMULATION OF AN ERGONOMICALLY OPTIMIZED  
NURSING CARE BED WITH INTEGRATED ACTUATOR SYSTEMS: A CASE  
STUDY AT KAWEMPE NATIONAL REFERRAL HOSPITAL**

**BY**

**WASSWA BETHEL RICHARD**

**(B.Eng. Mech. & Manuf. Eng. Kyu)**

**20/U/GMEM/13155/WKD**

**A DISSERTATION SUBMITTED TO THE DIRECTORATE OF RESEARCH  
AND GRADUATE TRAINING IN PARTIAL FULFILMENT OF THE  
REQUIREMENTS FOR THE AWARD OF MASTER OF SCIENCE  
IN ADVANCED MANUFACTURING SYSTEMS ENGINEERING  
DEGREE OF KYAMBOGO UNIVERSITY**

**OCTOBER, 2024**

## **DECLARATION**

I, Wasswa Bethel Richard, a candidate for the Masters of Science in Advanced Manufacturing Systems Engineering Degree at Kyambogo University, declare that this research dissertation is my original work and has never been presented for a degree at any other university, and no part of this dissertation is plagiarized work.

Sign. .... Date. ....

## APPROVAL

This dissertation entitled” *Design and Simulation of an Ergonomically Optimised Nursing Care Bed with Integrated Actuator Systems*” prepared and submitted by Wasswa Bethel Richard in partial fulfilment of the requirements for the Masters of Science in Advanced Manufacturing Systems Engineering Degree at Kyambogo University, has been supervised and is ready for examination.

Sign.  ..... Date. 23/10/2024 .....

Dr. Kangwagye Samuel

Sign..... Date. ....

Dr. Mukasa Perez

## **DEDICATION**

I dedicate this dissertation to the staff of the Department of Mechanical and Production Engineering at Kyambogo University, especially Dr Samuel Kangwagye, Dr Perez Mukasa, and Dr Maureen Nalubowa Ssempijja; my colleagues Bakubye John, Kyabaggu Jonathan, and Oriba Mathew; my children, Muwanguzi Jordan Lubanjwa, Mirembe Joselyn, Nanziri Tsubira Hannah Nakintu; and my beloved wife, Mrs. Namirimu Susan.

## **ACKNOWLEDGEMENTS**

I would like to acknowledge the power of the almighty God for the gift of life and protection from any form of accident he has offered freely through the entire course of study, glory is to God. I would also like to acknowledge the overwhelming academic support and effective supervision provided by Kyambogo University's Department of Mechanical and Production

Engineering, as well as my supervisors, Dr Samuel Kangwagye, Dr Perez Mukasa, and Dr Moureen Nalubowa Ssempijja, for their invaluable advice in helping me to finish my work. The suggestions and helpful critiques encouraged me to continue until the task was finished. In addition, I would like to thank my family for their understanding and assistance throughout this effort; without them, I could not have finished the task. My appreciation is extended to Kawempe Referral Hospital management for allowing me to conduct this research on their premises, and more so for their support and cooperation in providing me with the necessary information. Special thanks go to my GMEM colleagues, with whom we shared ideas and encouraged each other as we worked on our research projects.

## TABLE OF CONTENTS

<b>DECLARATION</b> .....	<b>i</b>
<b>APPROVAL</b> .....	<b>ii</b>
<b>DEDICATION</b> .....	<b>iii</b>
<b>ACKNOWLEDGEMENTS</b> .....	<b>iv</b>
<b>TABLE OF CONTENTS</b> .....	<b>v</b>
<b>LIST OF FIGURES</b> .....	<b>ix</b>
<b>LIST OF TABLES</b> .....	<b>xii</b>
<b>LIST OF ABBREVIATIONS</b> .....	<b>xiii</b>
<b>ABSTRACT</b> .....	<b>xiv</b>
<b>CHAPTER ONE: INTRODUCTION</b> .....	<b>1</b>
1.1 Background of the Study.....	1
1.2 Failure Analysis of Hydraulic Cylinder Actuator .....	3
1.3 Statement of the Problem .....	5
1.3.1 General Objective.....	5
1.3.2 Specific Objectives .....	5
1.4 Justification of the Study.....	6
1.5 Scope .....	6
<b>CHAPTER TWO: LITERATURE REVIEW</b> .....	<b>7</b>
2.1 Hospital Beds Overview.....	7
2.1.1 Manual Hospital Beds.....	8
2.1.1.1 Manual Hydraulic Bed .....	8

2.1.2 Semi-Electric Hospital Beds .....	9
2.1.3 Fully Electric Hospital Beds .....	9
2.2 Hospital Bed Actuation System Overview .....	10
2.2.1 Mechanical Actuators.....	10
2.2.2 Hospital Bed Adjustment Positions .....	20
2.3 Summary of Research Gap .....	23
<b>CHAPTER THREE: METHODOLOGY .....</b>	<b>25</b>
3.1 Research Design .....	25
3.2 Design Methods for the Bed Parts.....	25
3.2.1 Bed Base Frame .....	25
3.2.2 Bed Link Assembly .....	26
3.2.3 Top Bed Frame Assembly .....	26
3.2.4 Hinge Bolts.....	26
3.2.5 Caster Wheels.....	26
3.2.6 Electric Linear Actuator Drive for Height and Trendelenburg Adjustment .....	27
3.2.7 Electric Linear Drive Actuator for Head and Legs Adjustments .....	27
3.2.8 Electric Components for Automating the Nursing Care Bed .....	27
3.3 Procedure for Force Analysis and Design Optimization of Super Structure ...	28
<b>CHAPTER FOUR : DESIGN OF THE PROPOSED BED .....</b>	<b>29</b>
4.1 Design Overview .....	30
4.2 Actuator Selection .....	30

4.2.1 Mathematical Modelling of Height and Trendelenburg Actuator .....	31
4.2.2 Mathematical Modelling of Head and Legs Actuator.....	33
4.3 Design of the Bed Super Structure .....	33
4.3.1 Design of Top Bed Frame.....	34
4.3.2 Design of Link Bed.....	37
4.3.3 Design of Bed Base Frame .....	38
4.3.4 Design of Hinge Bolts.....	40
4.3.5 Design of Caster Wheels .....	41
4.4 Development of Control Circuit.....	42
4.4.1 Electric Components for Automating the Nursing Care Bed .....	43
4.4.2 Control Panel .....	45
4.4.3 Control System Design .....	45
4.5 Assembled Bed System .....	48
4.6 Performance Comparison Table .....	49
<b>CHAPTER FIVE:FORCE ANALYSIS AND DESIGN OPTIMIZATION .....</b>	<b>50</b>
5.1 Procedure for Force Analysis on Nursing Care Bed .....	50
5.1.1 Study Properties of Nursing Care Bed Super structure .....	51
5.1.2 Meshing information for Nursing Care bed Super structure .....	52
5.1.3 Material Properties of ASTM A36 Steel .....	55
5.2 Force Analysis Results and Discussions .....	57
5.2.1 Force Analysis Results for Top Bed Frame.....	57
5.2.2 Force Analysis Results for H Link.....	61

5.2.3 Force Analysis of Base Frame.....	65
5.2.4 Summary of Force Analysis Results.....	69
<b>CHAPTER SIX:SUMMARY, CONCLUSIONS, AND RECOMMENDATIONS</b>	
.....	<b>70</b>
6.1 Summary .....	70
6.2 Conclusion.....	70
6.3 Recommendations .....	71
6.4 Suggestions for Future Studies.....	71
<b>REFERENCES .....</b>	<b>72</b>
<b>APPENDICES .....</b>	<b>82</b>
Appendix A: Drawings.....	82

## LIST OF FIGURES

Figure 1. 1: Faulty beds due to faulty hydraulic cylinder actuator mounted at base .....	2
Figure 1. 2: Hydraulic cylinder actuator parts .....	3
Figure 1.3: Stress analysis for a hydraulic actuator with wiper seals and no wiper seal ...	4
Figure 2.1: Manual hospital bed (Ariyarit & Kittipichai, 2012). .....	7
Figure 2.2: Manual hydraulic hospital bed (Fazzino, 1995) .....	8
Figure 2.3: Semi electric hospital bed (Catalano & Coolidge, 2006). .....	9
Figure 2.4: Fully electric hospital beds (Gheri et al., 2018). .....	9
Figure 2. 5: Lead screw Actuator (Thomson, 2007) .....	11
Figure 2.6: Ball and Screw actuator (Hiwin,2024) .....	11
Figure 2. 7: Rack and Pinion Actuator (Chiaravalloti et al., 2007). .....	12
Figure 2.8: Hydraulic Cylinder Actuator (Components, 2023). .....	13
Figure 2.9: Single-Acting Hydraulic Actuator (Anjith, 2023). .....	14
Figure 2.10: Double-acting Hydraulic Actuator (Anjith, 2023). .....	15
Figure 2.11: Telescopic Hydraulic Actuator (Best Metal Products,2020). .....	15
Figure 2.12: Pneumatic Cylinder Actuator (Parker, 2015). .....	16
Figure 2.13: Worm Wheel (He et al., 2021). .....	18
Figure 2.14: Electric Linear Drive Actuator (Raversbergen, 2020). .....	19
Figure 2.15: Electric hydraulic Actuator (Hannifin, 2020). .....	19
Figure 2.16: Head adjustment position .....	20
Figure 2.17: Legs Adjustment position .....	21
Figure 2.18: Height adjustment position .....	21
Figure 2. 19: Trendelenburg Adjustments (Singh Bisht, 2020). .....	22

Figure 2.20: Post-Trendelenburg position (Xedus, 2024).....	23
Figure 4.1: Design flow chart for Nursing Care Bed.....	29
Figure 4.2: Free body diagram for forces acting on the height adjustment linear actuator .....	30
Figure 4. 3: Free body diagram for forces acting on the head and legs adjustment linear actuators .....	32
Figure 4.4: Top Bed frame .....	34
Figure 4. 5: Free body diagram for NCB Top Frame .....	34
Figure 4.6: H Bed link.....	36
Figure 4.7: Bed Base Frame.....	38
Figure 4. 8: Free body diagram for bed base frame .....	38
Figure 4.9: Caster Wheel.....	41
Figure 4.10: Block Control Circuit Diagram for Nursing Care Bed.....	42
Figure 4.11: Electric control circuit for Nursing care bed .....	45
Figure 4.12: Block Diagram for design Table .....	47
Figure 4. 13: Nursing care bed.....	48
Figure 5. 1: Stress plot for top bed frame .....	56
Figure 5. 2: Displacement plot for Top Bed Frame .....	57
Figure 5. 3: Strain plot for top bed frame .....	59
Figure 5.4: Factor of safety plot for top bed frame .....	60
Figure 5.5: Stress plot for H link.....	61
Figure 5.6: Displacement plot for bed link .....	62
Figure 5.7: Strain plot for H link.....	63

Figure 5.8: Factor of safety for H link .....	64
Figure 5.9: Stress plot for Base Frame.....	65
Figure 5.10: Displacement plot for bed base frame .....	66
Figure 5. 11: Strain plot for bed base frame .....	67
Figure 5. 12: Factor of safety for base frame .....	68

## LIST OF TABLES

Table 3.1: Mechanical parts for the Nursing Care Bed.....	25
Table 4. 1: Force height adjustment linear actuator .....	31
Table 4.2: Forces on head and leg rest linear actuator .....	32
Table 4.3: Top bed frame, link, and base dimensions.....	33
Table 4. 4: Normal and Bending stress .....	36
Table 4.5: Electrical parts for Nursing Care Bed.....	42
Table 4.6: Nursing care bed part. ....	47
Table 4.7: Hospital Bed performance Comparison Table.....	49
Table 5. 1: Study properties for the mechanical part of the bed. ....	51
Table 5.2: Mesh information for top frame.....	52
Table 5. 3: Mesh information for Base Frame .....	52
Table 5. 4: Mesh Details for Top Frame .....	53
Table 5.5: Mesh details for Base Frame.....	54
Table 5. 6: Material properties for ASTM 36A material .....	55
Table 5. 7: Summary of Force Analysis Results.....	69

## **LIST OF ABBREVIATIONS**

ASTM	American Society for Testing and Materials
A36	Ferrous metal with Yielding Strength 36,000 psi
COPD	Chronic Obstructive Pulmonary Disease
CNC	Computer Numerical Control
FDA	Food and Drug Administration
ICU	Intensive Care Unit
KNRH	Kawempe National Referral Hospital
MOH	Ministry of Health
PVC	Polyvinyl Chloride
NCB	Nursing Care Bed
NDP	National Development Plan
SDGs	Sustainable Development Goals
UDL	Uniformly distributed load

## ABSTRACT

The scarcity of nursing care beds and appropriate medical equipment are two of the biggest issues facing healthcare facilities Uganda. This dissertation presents the design and simulation of a nursing care bed with integrated electric linear actuator systems capable of adjusting height, legs, head, Trendelenburg, and post-Trendelenburg positions to enhance patient comfort and care. The nursing care bed integrates multiple electric linear actuators and electric control system to provide a comprehensive range of adjustments, allowing for positioning tailored to individual patient and medical personal needs. The design prioritizes ergonomic principles and control systems to ensure smooth, and precise bed adjustments. Detailed simulations were conducted to assess the performance and reliability of the bed's mechanisms, focusing on actuator coordination, load distribution, and user safety. The results indicate that the nursing care bed system was effective and the results were; factor of safety for top frame was 2.655, factor of safety for bed link was 2.41 and factor of safety for base frame was 2.273 all were above 1.5. Similarly, the stresses on nursing care super structure were below the yield strength of ASTM- A36 which is  $2.5 \times 10^8 \text{N/m}^2$ . The top frame had stress of  $9.416 \times 10^7 \text{N/m}^2$ , bed link stress was  $1.07 \times 10^8 \text{N/m}^2$ , and base frame stress was  $7.626 \times 10^7 \text{N/m}^2$ . Additionally, electric linear Actuator selection was done through force analysis and optimization by analyzing forces at different angle of inclination to obtain the suitable actuator rating. The head and legs electric actuators optimized loading capacity was 539.55N, and height adjustment electric actuator optimized loading capacity was 2403.5N. Utilizing a electric linear actuator actuator system proved to be cost effective than hydraulic actuation system since no routine maintenance such as; change of oil seals, topping up of hydraulic oil activities among other was required for Nursing Care Bed.

## **CHAPTER ONE: INTRODUCTION**

### **1.1 Background of the Study**

Economic growth and development are significantly impacted by the standard of healthcare provided (Finlay, 2007). An insufficient healthcare system affects society politically, economically, culturally, and socially (Javed et al., 2019). Similarly, poor-quality health services have a direct impact on patient satisfaction, medical expenses, and quality of life (Forrellat Barrios, 2014).

In many countries, improving the health system is crucial to achieving equitable access to universal healthcare (Laokri et al., 2018). Specifically, hospital beds are some of the essential features of healthcare facilities since they have a direct impact on patient care, healing, and overall well-being (Shrikrishna, 2022). Also, they technically aid healthcare professionals in treating patients more efficiently while also providing comfort (Ariyarit & Kittipichai, 2012).

Furthermore, health professionals use hospital beds to transport patients within hospitals (Ando et al., 2000).

According to Onkar and Furnitech (2014), a significant percentage of people are bedridden due to various illnesses, accidents, and surgeries. This created a scarcity of hospital beds within health facilities. Additionally, obtaining and using appropriate medical equipment is one of the challenges facing healthcare systems in developing nations (Eze et al., 2019). There is an instant demand for an affordable and adaptable hospital bed alternative in healthcare settings with limited resources.

In this regard, Kawempe National Referral Hospital (KNRH) utilizes hydraulic actuated hospital beds to aid its obstetrics and gynaecological health care services. However, these beds hinder patient care due to hydraulic cylinder actuator failures resulting from piston rods getting stuck in the cylinder gland. Faulty beds are illustrated in Figure 1.1. This challenge was also noticeable in Uganda's health facilities, such as Kiruddu and Mulago. Besides that, several designs for hospital beds have been proposed to lessen the exceptional workload on medical professionals.



**Figure 1. 1: Faulty beds due to faulty hydraulic cylinder actuator mounted at base**

The designs consider a variety of factors, including mechatronic design, intelligent systems, control systems, and mechanism design (Ching-hua et al., 2007, Peng et al., 2010, Seo et al., 2005). Automated beds are known for addressing the requirements of end users in terms of practical and ergonomic adjustments but their initial and maintenance costs are high, rendering them unfeasible options for financially constrained nations such as Uganda (Duarte & Naveiro, 2020). According to Pugin (2020), 40% of

all operational expenses are related to equipment maintenance. This is also reflected in the sizable amount of cost incurred by healthcare facilities that utilize hydraulic beds.

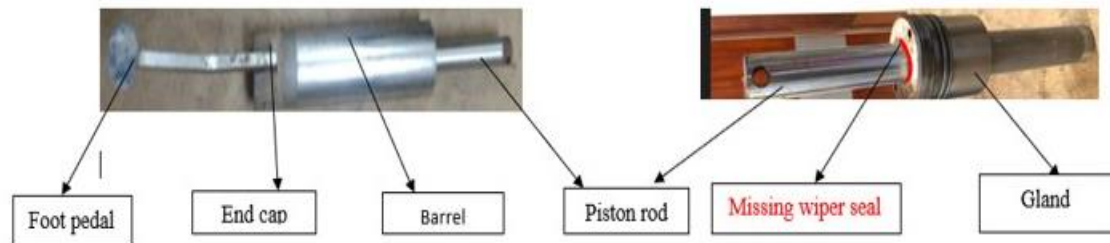

**Figure 1. 2: Hydraulic cylinder actuator parts**

In this study, the research aimed at designing and simulating a nursing care bed that utilizes four electric linear drive actuation systems for head, legs, height, and Trendelenburg positions to meet the specific needs and requirements of healthcare systems, which will enhance patient care and reduce maintenance costs on medical equipment in hospitals is conducted.

### **1.2 Failure Analysis of Hydraulic Cylinder Actuator**

Hydraulic hospital beds in KRNH utilize hydraulic cylinder actuators mounted at the bottom of beds and are operated by foot, which raises and lowers the hospital bed height. The facility has 200 beds; in 2022, as per the KNRH inventory report, 40% of these beds had developed failures related to the hydraulic actuation system, as depicted in Figure 1.2 where the cylinder pump piston rod gets embedded into the cylinder pump gland. This failure affects the bed's height adjustments and is attributed to a missing wiper seal that prevents moisture and other foreign substances from entering the cylinder pump barrel.

Besides that, a missing wiper seal causes the surfaces to clog between the cylinder gland and the cylinder pump piston rod and also, blocks the cylinder pump end cap oil passage.

Results from the von Mises stress analysis in Figure 1.3 revealed that hydraulic cylinder pumps featuring a wiper seal were more effective, with a maximum stress of  $4.421 \times 10^6 \text{Nm}^2$  as compared to those without a wiper seal of  $7.52 \times 10^6 \text{Nm}^2$ . However, installing wiper seals to achieve the minimum stress requirement has proven to be expensive, where a single

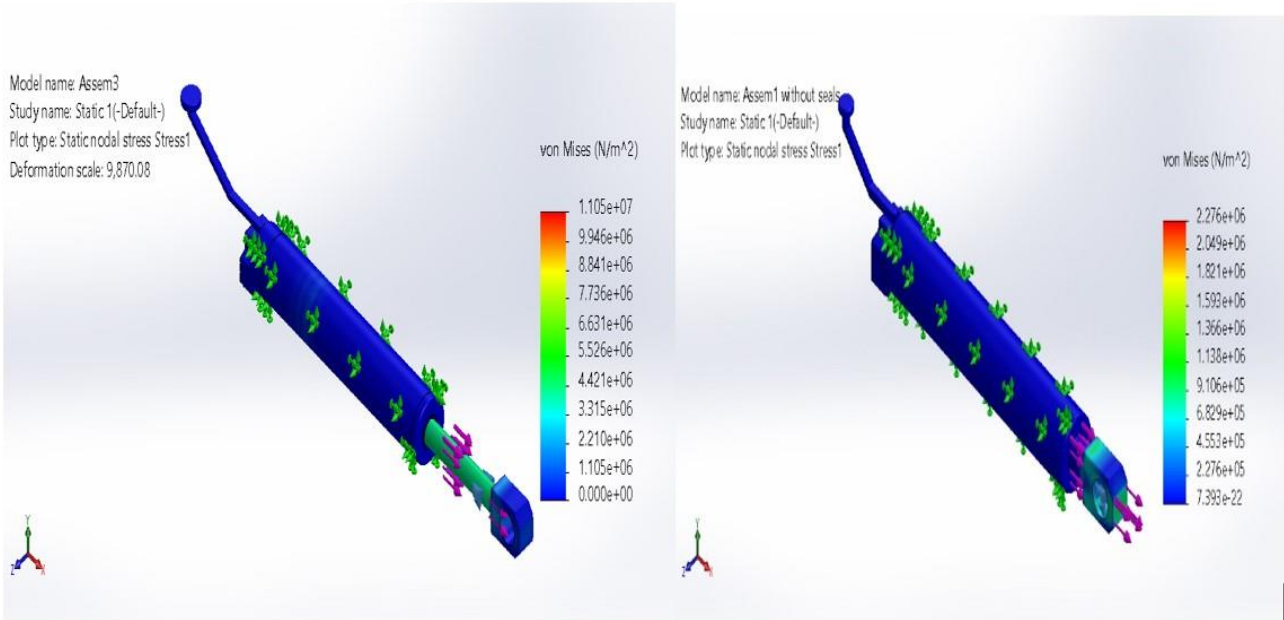

**Figure 1.3: Stress analysis for a hydraulic actuator with wiper seals and no wiper seal**

seal goes for 50,000 to 200,000 Ugx, depending on material and design (Totally Seals, 2023), and it is also not a lasting solution for the problem. Additionally, the cost of maintenance associated with the hydraulic cylinder pump is high (Pyramid, 2024), and

their spare parts are scarce on the local market; therefore, this prompts an alternative for the design of a hospital bed with a different actuation system.

### **1.3 Statement of the Problem**

Hydraulic-cylinder actuators fail quite often due to fail seals, corrosion and fluid contamination (Energy, 2021). Specifically, these failures affect hospital beds that utilize hydraulic actuator during bed adjustments and hinder the delivery of medical services within the facility. Additionally, their repair costs are high as compared to other types of actuators, these include routine change of oil, replacement of oil seals among others. for instance, a single hydraulic cylinder actuator for height adjustment costs 2.5 million Ugx (Industry, 2020). Besides that, most of their associated spare parts are not accessible on the local market. This therefore prompts for an alternative actuation mechanism to mitigate the above challenge.

#### **1.3.1 General Objective**

The main objective of the study is to design and simulate an ergonomically nursing care bed with integrated electrical actuator systems.

#### **1.3.2 Specific Objectives**

The specific objectives are:

- i)** To size the electrical linear actuation system of nursing care bed.
- ii)** To size and select material of nursing care bed super structure.
- iii)** To conduct force analysis on nursing care bed super structure.
- iv)** To develop a control circuit for nursing care bed.

#### **1.4 Justification of the Study**

Kawempe National Referral Hospital's primary objective is to provide obstetrics and gynaecological care. According to the KNRH daily report, the aforementioned institution typically admits 50–85 mothers in the labour ward, 20–28 mothers for a caesarean section in the theatre, 8–13 mothers in the gynaecology emergency ward, and one mother in the private wing, for a total of about 100 mothers per day. These mothers are inpatients and occupy these beds while they are receiving medical care. Therefore, if the challenge with hospital bed actuation design is not resolved, fewer hospital beds are likely to be utilized, making the majority of them obsolete. Consequently, Uganda may not meet the NDP 111 and the SDGs regarding maternal and child health. Additionally, this makes it harder for health professionals to provide health services, which hinders the MOH's vision for 2040.

#### **1.5 Scope**

This study was limited to the design and simulation of a 200-kilogram nursing care bed since the majority of patients' weights are between (35 and 150) kilograms on average. The study entailed the design and simulation of nursing care bed adjustments that included: head, legs, Trendelenburg, and post-Trendelenburg adjustment and the development of an automated actuation system.

## CHAPTER TWO: LITERATURE REVIEW

### 2.1 Hospital Beds Overview

Hospital beds are medical equipment that are designed for patients undergoing several kinds of treatments and for healthcare professionals applying various controls when conducting medical procedures (Profile, 2013). They also play a significant role in the provision of high-quality patient care in healthcare settings (Drayi, 2019). Furthermore, they support medical professionals in diagnosing, monitoring, and treating patients with various health related conditions (Dartey et al., 2021).

Hospital beds were previously classified as medical furniture. However, the US Food and Drug Administration (FDA) defined hospital beds as medical equipment as opposed to medical furniture due to the needs of several regulations for operations such as inpatient treatment, patient care, patient follow-up, and heavy usage (Weinger, 2010). Due to their cost and diversity, these beds often appear in a range of healthcare settings. They are available in a variety of forms, which include fully electrical beds, semi-electric beds, and manual operating beds (Nikamel, 2024), to suit a range of patient needs.



**Figure 2.1: Manual hospital bed (Ariyarit & Kittipichai, 2012).**

### **2.1.1 Manual Hospital Beds**

Manual hospital bed operation utilizes hand cranks that raise the head, foot, and bed frame. As seen in Figure 2.1 (Ariyarit & Kittipichai, 2012), a range of bed positions are offered to meet patient needs. The bed gives patients comfort and support by incorporating features that allow them to adjust the 's head and foot positions. It also does not require electricity and is easy to operate. These beds offer a cost-effective option for long-term care. (Medik, 2022). In contrast to their merits, they are slower and less efficient than electric versions. They also require an attendant for their operation when the need arises as compared to electric versions.



**Figure 2.2: Manual hydraulic hospital bed (Fazzino, 1995)**

#### **2.1.1.1 Manual Hydraulic Bed**

The bed design has a variable height, which is achieved through the use of a hydraulic cylinder pump. The pump assembly is mounted on the bed base frame, where the operator applies force through a foot-pumping mechanism. It's also composed of a set of castor wheels with brakes that are mounted at the base frame to allow easy movement, as seen in Figure2.2 (Fazzino, 1995)



**Figure 2.3: Semi electric hospital bed (Catalano & Coolidge, 2006).**

### **2.1.2 Semi-Electric Hospital Beds**

Semi-electric beds combine electric and manual controls, where the bed's head and foot adjustments are done by hand and the height adjustment is electrically driven (Nazaria, 2023) as shown in Figure 2.3. This function makes it convenient for caregivers and patients since changing the bed's height is a routine task that requires no effort. They are more efficient as compared to manual bed versions and require fewer efforts for bed adjustments (Expert, 2024). However, they are relatively costly as compared to manual beds. Additionally, it requires some effort during head and foot adjustment that a patient can't achieve in the absence of an attendant.



**Figure 2.4: Fully electric hospital beds (Gheresi et al., 2018).**

### **2.1.3 Fully Electric Hospital Beds**

Electric beds are adjusted using electric actuators. They are especially helpful for people with a range of health challenges that make it difficult for them to sleep in unpleasant postures (Portea, 2022). An electric hospital bed enables height adjustment and provides the ideal height for caregivers to work with patients. It also raises the head to a position similar to Fowler's to facilitate feeding, breathing, and other benefits of reclining upright, and it raises the feet to facilitate blood flow and ease of movement (Biolab, 2024). Collapsible guard rails that are powered by electricity, a variety of resting positions, compatibility with hospital bed mattresses, removable head and foot boards, and swivel castors are some of the key characteristics of electric beds, as illustrated in Figure 2.4 (Gherzi et al., 2018). These beds are adaptable enough to be used in hospitals, rehabilitation facilities, nursing homes, and home care settings since they include electric mechanisms. They are more efficient as compared to manual and semi-electric beds (Water Orthopedics, 2024). However, their cost and maintenance are high for low-income countries as compared to other bed versions.

## **2.2 Hospital Bed Actuation System Overview**

Hospital bed height actuation systems are intended to provide the ability to raise or lower beds, to enhance patient safety, comfort, and ease of care for both patients and medical personnel.

### **2.2.1 Mechanical Actuators**

Mechanical actuators are devices that convert one type of motion into another for instance form rotary to linear motion (Rao, 2023). They work by utilizing various devices such as

gears, chains, screws, pulleys, and rails. They frequently work in conjunction with additional motors and driving mechanisms.



**Figure 2. 5: Lead screw Actuator (Thomson, 2007)**

#### **(a) Lead Screws Actuation System**

These screws use direct sliding friction to convert torque into linear motion. A typical setup consists of a nut and a steel screw, as shown in Figure 2.5. Lead screw actuators are an affordable option that can handle large static forces, withstand significant vibration, and operate quietly (SKF, 2018). Similarly, they have a low maintenance cost, are easy to manufacture, and are self-locking (Dhaware et al., 2019). Acme, trapezoidal, and square thread profiles are the most commonly utilized thread profiles in lead screws. Although square threads are more efficient, have weaker fundamentals. Their manufacture is also expensive. Trapezoidal threads have a higher payload-carrying capability because they are easier to make and have a thicker root than other thread types.



**Figure 2.6: Ball and Screw actuator (Hiwin,2024)**

### **(b) Ball and Screw System**

The ball screw drive is an assembly that converts rotary motion to linear motion. It comprises a ball screw and a ball nut package as an assembly with recirculating balls, as seen in Figure 2.6. The interface between the ball screw and the nut is made of balls. With rolling elements, the ball screw drive has a reduced friction coefficient, so the efficiency is greater than 90% (Dhaware et al., 2019). A lack of stick and slip phenomenon that results in durability, less wear and tear, a lower beginning torque requirement, load capacity, fatigue life, and excellent position accuracy (Zhang, Zhou, & Feng, 2023). They can be used for highspeed operations, are noiseless during operation, and have high reliability and durability. Besides that, the above system has its drawbacks, which include being more expensive as compared to lead screws, having a serious buckling effect at critical speeds, requiring thin film lubrication for satisfactory operation, needing periodic overhauling to maintain their efficiency, and lacking self-locking properties.



**Figure 2. 7: Rack and Pinion Actuator (Chiaravalloti et al., 2007).**

### **(c) Rack and Pinion Actuation System**

There are two gears in a rack and pinion gear set, as shown in Figure 2.7 (Chiaravalloti et al., 2007). The rack is made of a straight helical gear, and the pinion gear is a typical

helical gear. The pinion gear's teeth mesh with the teeth of the rack. The rack and pinion gear are an example of a well-designed device that reduces time and labour. To transition between rotary and linear motion, a rack and pinion are utilized. With a rack and pinion, it can also shift from rotary to linear motion or the other way around. Rack and pinion gears are useful in a variety of applications due to their high-power transmission efficiency, which is a result of the direct contact between the teeth on the rack and the pinion gear, this minimizes energy loss and results in efficient motion transfer. The efficiency makes rack and pinion gear appropriate for applications that need precise and quick linear motion, compact size; limited space (Zhygear, 2023). Additionally, due to the simplicity of the gear system, manufacturing and maintenance costs can be reduced. However, they do have some drawbacks, such as reduced top speed increased noise, and incorrect engagement at the rack portion's beginning (Adenwela, 2023).

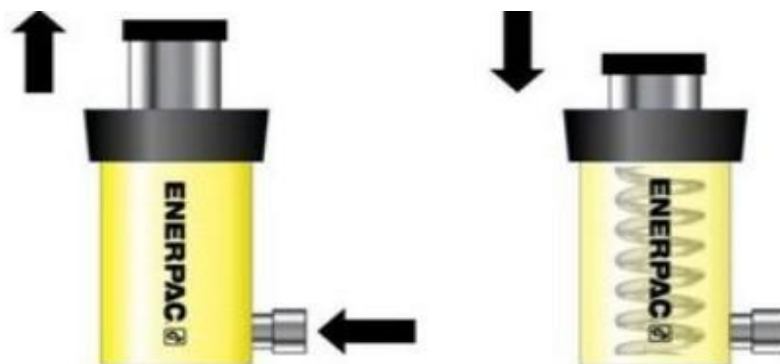

**Figure 2.8: Hydraulic Cylinder Actuator (Components, 2023).**

#### **(d) Hydraulic Cylinder Actuator**

A hydraulic cylinder actuator is a device that converts fluid pressure energy into mechanical form (Silar, 1980). The piston is subjected to pressure from the working fluid, which generates a force that moves the piston assembly and consequently, the piston rod does beneficial work (Bohman, 2017), as seen in Figure 2.8. The ability to obtain huge

working forces and low operating speeds constitute only two of the many benefits of these structures (Uzny & Kutrowski, 2019). The most common types of hydraulic actuators include single-acting, double-acting, and rotary actuators. They are capable of producing high speed, high power, and holding constant force without pumping, consuming extra energy to supply fluids to the cylinder as they use incompressible fluids. Although hydraulic cylinders are durable equipment, their optimal operation necessitates regular maintenance (Lewis, 2024). Since the rod and piston seals are the primary components that contain pressure, it is imperative to maintain their integrity. Regular oil and filter changes are necessary because deteriorated oil impairs system performance, which makes them costly. A leakage in the fluid may result in a loss of efficiency, and the fluids can also impact the environment adversely (Lloyd Leugner, 2024). They are also not suitable for extreme temperatures, as the fluid properties may vary depending on the temperature (Hashim et al., 2022). Hydraulic actuators have a lot of components, such as reservoirs, pumps, release valves, heat ex changers, etc., which can result in lower reliability and higher resources for monitoring, thus increasing the cost of operations.



**Figure 2.9: Single-Acting Hydraulic Actuator (Anjith, 2023).**

### **Single-Acting Hydraulic Actuator**

Single-acting cylinders only operate in one direction, as illustrated in Figure 2.9 (Anjith, 2023). This limits the cylinder's motion when an oil flow is supplied. An external force is needed to return the oil to the pump or system so that this cylinder can move back to its initial position.

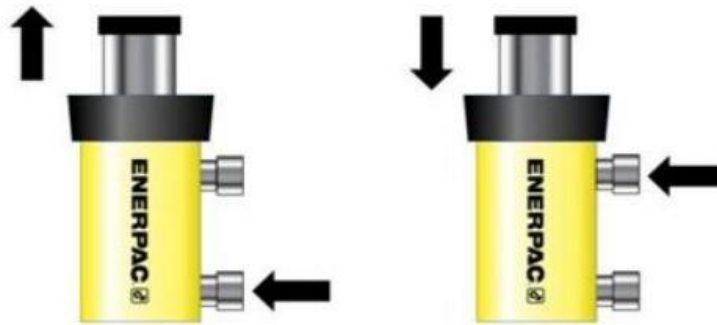

**Figure 2.10: Double-acting Hydraulic Actuator (Anjith, 2023).**

### **Double-Acting Hydraulic Actuator**

Double-acting hydraulic actuators are of the form that transfers fluid pressure in a two-way direction. They are commonly utilized in applications where motion control is required in a two-way direction as seen in Figure 2.10. They comprise two ports for oil exit and entry control, piston, and piston rod. Besides that, several oil seals are incorporated into the assembly to stop oil leakages.



**Figure 2.11: Telescopic Hydraulic Actuator (Best Metal Products,2020).**

### **(i) Telescopic Hydraulic actuator**

There are two types of hydraulic telescopic cylinders: single-acting and double-acting (Lewis, 2022). Similarly, they are also referred to as multistage cylinders. Compared to the others, this specific type of cylinder has a longer stroke length that collapses to the length of 20–40 % of its expanded length as seen in Figure 2.11 (Best Metal Products, 2020). The key benefit of these cylinders is their ability to be used efficiently in limited-space areas, while extending or retracting, they can be set up so that every moving stage extends at the same duration, maintaining a steady force and speed. There are two types of hydraulic telescopic cylinders: single-acting and double-acting (Lewis, 2022). Similarly, they are also referred to as multistage cylinders. Compared to the others, this specific type of cylinder has a longer stroke length that collapses to the length of 20–40 % of its expanded length as seen in Figure 2.11 (Best Metal Products, 2020). The key benefit of these cylinders is their ability to be used efficiently in limited-space areas, while extending or retracting (Hydro, 2024). They can be set up so that every moving stage extends at the same duration, maintaining a steady force and speed.



**Figure 2.12: Pneumatic Cylinder Actuator (Parker, 2015).**

### **(f) Pneumatic Cylinder Actuator**

The principles underlying the operation of hydraulic and pneumatic actuators are highly comparable. Pneumatic actuators differ primarily in that compressed air, which is more compressible than liquids, is employed in place of fluid in these devices, as depicted in Figure 2.12 (Parker, 2015). Utilizing pneumatic actuators for linear motion control applications allows them to produce high force and rapid movement; pneumatic actuators don't overheat unlike other devices (John Rowse, 2024). In applications where hygiene is crucial, pneumatic actuators are the recommended choice of device (Ryan King, 2020). This is mostly because compressed air is free of hazardous chemicals, protecting the application from contamination. Naturally, in the food and beverage and pharmaceutical businesses, this is crucial. Besides that, there is reasonable noise and vibration produced by pneumatic actuators during operation, which is a potential discomfort to operators (Shanghai, 2024). The release of compressed air produces audible sound and mechanical vibrations. Also, pneumatic actuators are not as energy-efficient as electrical actuators, but they are generally more energy-efficient than hydraulic systems (Sendath, 2024).

The lower overall efficiency is a result of some energy being lost as heat during the compression and expansion of air. Alternative actuation technologies might be more appropriate in applications where energy conservation is a top concern. The comparatively low accuracy and control of pneumatic actuators in comparison to other actuation methods is also a major issue. Pneumatic actuators are less appropriate for applications needing high accuracy and tight tolerances because air compression can

result in small differences in motion and placement (Hankun, 2022). Compared to hydraulic systems of the same size, pneumatic systems have a much lower load capacity.

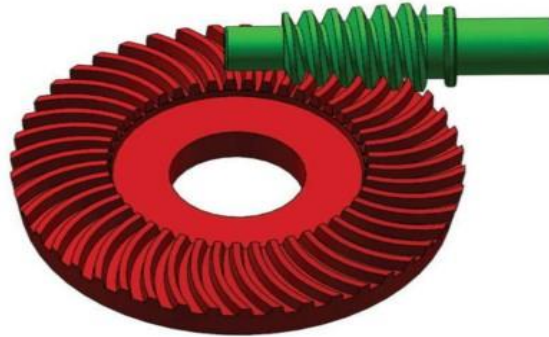

**Figure 2.13: Worm Wheel (He et al., 2021).**

#### **(g) Worm Wheel**

As seen in Figure 2.13, the worm screw -like part and wheel gear make up the worm gear system, they are positioned across one another. They are used in many different applications, including presses, elevators, and cars. Normally they are known for their high-speed reduction and silent, smooth operation when engaged (Premium, 2024). The mechanical advantage offered by this type of actuation mechanism is significant. They are typically used in places where making noise is not necessary. Nevertheless, the worm wheel actuation technique has drawbacks, including complications in manufacturing and maintenance (Extruder, 2024).

#### **(h) Electrical actuators**

The fundamental idea behind how electric actuators function is that they transform electrical energy into mechanical motion (Ruben, 2023). Electric actuators are powered by electricity and move through small electrical motors connected to belts, chains, gears, or tracks (Price, 2022). Because of their extreme flexibility and efficiency, electric

actuators are thought to be able to produce motions that are more precise than those made by other means(Tang, 2024).



**Figure 2.14: Electric Linear Drive Actuator (Raversbergen, 2020).**

**(i) Electric Linear drive actuator**

Figure 2.14 (Raversbergen, 2020) shows an electric linear actuator. They are devices that transmit motion in a straight path as compared to electric motors that generate circular motion (Fenske, 2023). They are used in several applications such as industrial machinery lifts and machine tools (Link, 2024). Electric linear actuators are energy efficient, maintenance free (Timotion, 2023). Additionally, they don't leak hydraulic oil, are less noisy and can work for longer periods.

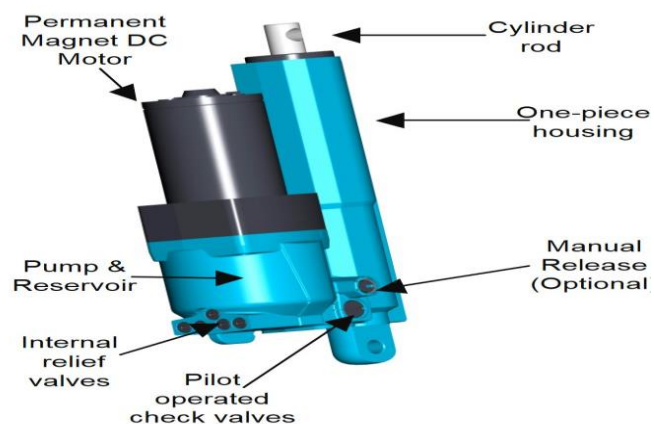

**Figure 2.15: Electric hydraulic Actuator (Hannifin, 2020).**

### **(ii) Electro-hydraulic Actuators**

Figure 2.15 (Hannifin, 2020) shows an Electro-hydraulic Actuator. This combines electrical and hydraulic systems to create motion. They are utilized in heavy-duty applications like controlling aircraft flaps, machinery, and industrial processes requiring high force and precise control.

### **2.2.2 Hospital Bed Adjustment Positions**

The five adjustments on a NCB are considered functions. Usually, there are height, foot, head (or back), Trendelenburg, and reverse Trendelenburg adjustments.

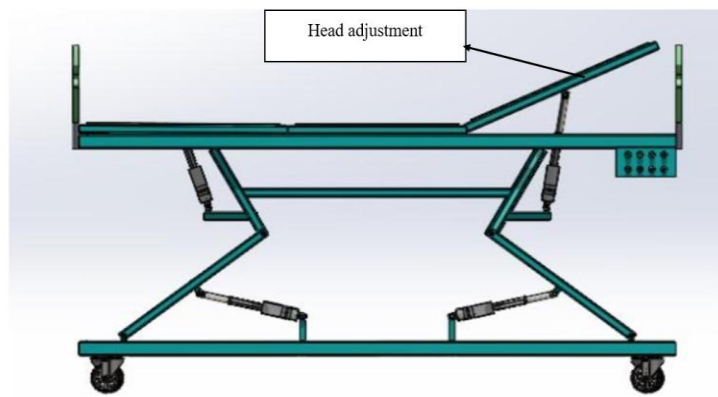
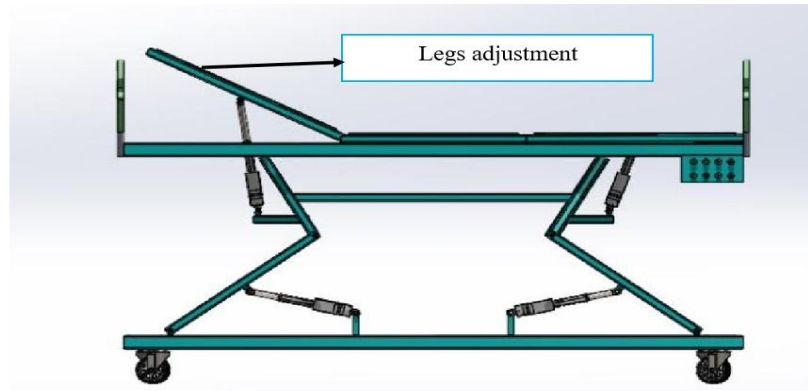

**Figure 2.16: Head adjustment position**

#### **(a) Head Adjustment**

The upper portion of the NCB is adjusted by adjusting the head or backrests, as seen in Figure 2.16. It normally uses a mechanically cranked mechanism or electrically controlled linear actuators. It can move in a flat to almost vertical range. The most obvious use for the head adjustment is to sit up in bed; however, elevated resting and sleeping positions are beneficial for a variety of illnesses because they lessen the strain on their lungs. People

with respiratory disorders, including chronic obstructive pulmonary disease (COPD), are frequently recommended to sleep in a semi-recumbent position (Werner, 2024).



**Figure 2.17: Legs Adjustment position**

**(a) Legs Adjustment**

The legs can be raised and lowered using the foot adjustment as illustrated in Figure 2.17. For patients with heart and circulation problems, who are frequently recommended to rest with their legs elevated to avoid blood pooling and swelling in the lower limbs, this adjustment is crucial (Jill Seladi-Schulman, 2021).

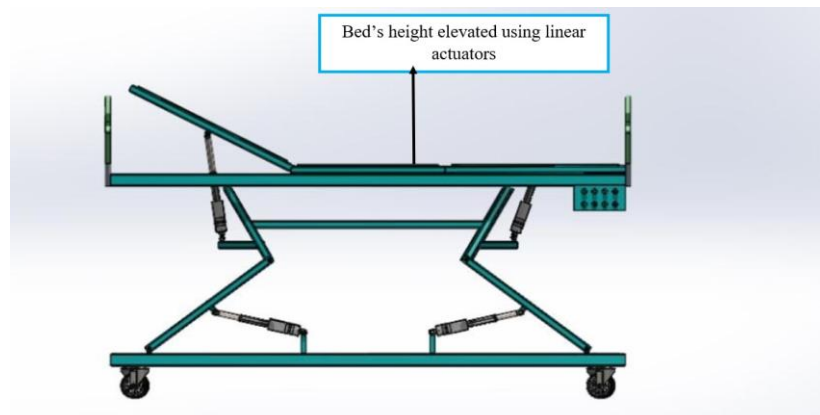

**Figure 2.18: Height adjustment position**

### **(c) Height Adjustment**

One of a nursing care bed's most important safety and convenience features is the height adjustment, sometimes referred to as the high-low adjustment. As seen in Figure 2.18, it allows the bed to be raised to an ergonomic height for patient care by a caregiver or healthcare provider. Individuals with limited strength or mobility should refrain from rising or falling from an excessively high or low bed. The bed may be raised or lowered to the perfect distance from the floor using the height adjustment.

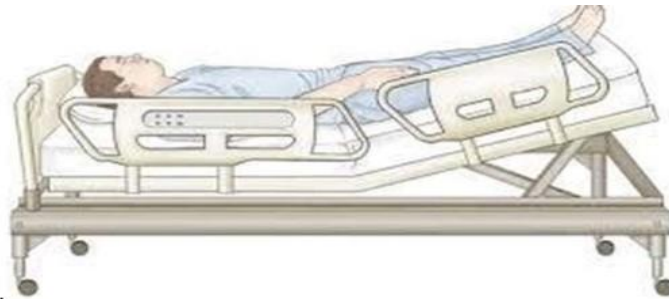

**Figure 2. 19: Trendelenburg Adjustments (Singh Bisht, 2020).**

### **(d) Trendelenburg Adjustments**

With the Trendelenburg adjustment, the surface of the bed is tilted, allowing the head to be lowered and the legs to be raised while the surface stays flat, as illustrated in Figure 2.19 (Singh Bisht, 2020). The Trendelenburg Position, in which the patient is placed on their back at a 15–30 degree (Rich, 2019). This position is a common tool used by medical practitioners, especially for patients with respiratory or circulatory disorders and during some procedures (Baker, 2023).



**Figure 2.20: Post-Trendelenburg position (Xedus, 2024).**

#### **(f) Post-Trendelenburg position**

When the patient is placed on an inclination so their head is higher than their feet as shown in Figure 2.20 (Xedus, 2024), they are in the post-Trendelenburg position. The angle of inclination usually varies from 15 to 30 degrees, much like the Trendelenburg position. There are several advantages to this position: It helps to improve lung expansion and oxygenation. Because it lessens acid reflux, it helps in cases of a condition called gastroesophageal reflux disease (Mathieu, 2016), It offers enhanced access to the thoracic and upper abdominal organs during surgery.

### **2.3 Summary of Research Gap**

Intensive Care Unit (ICU) hospital beds are comfortable and easy to use, this is why they are frequently recommended for patients with multiple illnesses that require a change in posture (Bajaj, 2024). They are unfeasible for medical facilities with limited funding and resources, due to high initial setup and maintenance cost. Acquiring manual-operated beds is less expensive than acquiring other types of beds, but caregivers must use a lot of effort

to operate them. The ideal initial and ongoing costs of a nursing care bed make it a desirable choice as compared to ICU and manual hospital beds.

## CHAPTER THREE: METHODOLOGY

### 3.1 Research Design

Both qualitative (review of literature) and quantitative (design and simulation) research methods were used in this study. The following steps were employed: sizing and material selection for the bottom bed frame, bed link assembly, top bed frame, and caster wheels, as illustrated in Table 3.1.

**Table 3.1: Mechanical parts for the Nursing Care Bed.**

No	Part description	Material selection	Dimension(mm)	Quantity
1	Top bed frame	Rectangular mild steel hollow section	2000 x 880	01
2	Bed link assembly	Rectangular mild steel hollow section	407 x 400	02
3	Base bed frame	Rectangular mild steel hollow section	2000 x 400	01
4	Hinge Bolts	Alloy steel	$\phi 14 \times 80$	08
5	Caster wheels	Pvc and rubber surfacing	$\phi 100.8$	04

### 3.2 Design Methods for the Bed Parts

#### 3.2.1 Bed Base Frame

The lower portion of the bed, referred to as its base frame, is where the two H bed links, two electric linear actuators, and the Custer wheels are positioned. ASTM A 36 steel hollow section material was used for the design. Solid Works was used to select and size the material for this bed component.

### **3.2.2 Bed Link Assembly**

The link assembly consists of two H links with a variable inclination angle. Links transmit the force generated by the electric linear drive. They were designed from ASTM-A36 hollow square steel material. Seizing and material selection for links was achieved using Solid Works software. The height adjustment depends on the movement of the inclined links at variable angles as the angle decreases the height also reduces.

### **3.2.3 Top Bed Frame Assembly**

The top bed frame is part of the bed which supports the patient while sleeping or resting. It was designed from (ASTM-A36) hollow rectangular steel material. It houses two electric linear drives for head and leg adjustments and supports the back and headrest plastic panels at the front and rear points of the bed, respectively. Seizing and material selection for these frames were achieved using Solid Works software.

### **3.2.4 Hinge Bolts**

The coupling of the top bed frame and link assembly was achieved by using hinge bolts that provided a hinge mechanism for flexibility. Similarly, they were utilized to couple the link assembly and the bed base frame. Seizing and material selection for these frames were achieved using Solid Works software.

### **3.2.5 Caster Wheels**

A caster wheel provides mobility for the hospital bed. They were selected from polyvinyl chloride (PVC) and rubber materials, with a brake system installed, to stop bed movement while being utilized on the ward and enhanced the patient's safety. Sizing and material

selection were achieved by computing the total weight exerted on the bed and using the available manufacturer catalogue to select the best caster wheels.

### **3.2.6 Electric Linear Actuator Drive for Height and Trendelenburg Adjustment**

Two electric linear drive actuators were adopted for height, Trendelenburg, and Post - Trendelenburg bed adjustments. The actuators comprise a lead screw and motor assembly as the major parts. The selection was based on performing a force analysis and computing the load exerted on actuator to obtain the force magnitude, that was used for actuator selection from the manufacturer's catalogue.

### **3.2.7 Electric Linear Drive Actuator for Head and Legs Adjustments**

The head and leg adjustments, comprised of one electric linear drive actuators each of the same rating, their main components were a motor assembly and a lead screw. The selection was based on performing a force analysis and computing the force on the actuator to obtain the force magnitude on each electric linear actuator, that was used for the selection from the manufacturer's catalogue.

### **3.2.8 Electric Components for Automating the Nursing Care Bed**

The electric circuit was developed to control the height adjustment, head adjustment, leg adjustments, and Trendelenburg adjustment positions for the Nursing care bed. The selection of electrical parts for a nursing care bed involved several considerations to ensure safety, reliability, and compatibility with the bed's electrical system.

### **3.3 Procedure for Force Analysis and Design Optimization of Super Structure**

To simulate a mechanical component for a nursing care bed in Solid Works, the process started by creating or importing the 3D model of the component and simplifying it to remove unnecessary details. Then, open Solid Works Simulation from the Simulation tab or add in to create a new study by selecting the appropriate type of analysis, such as static, dynamic, thermal, or frequency analysis. It followed the assignment of material properties to the component, including elastic modulus, Poisson's ratio, and density. Furthermore, define the boundary conditions by applying fixtures to constrain the component and specifying the loads, such as forces, pressures, or thermal effects. Furthermore, the generation of a finite element mesh to divide the model into smaller elements and refine the mesh in critical areas for greater accuracy. A simulation was then run to solve the governing equations based on the defined conditions. When the simulation was complete, the results were analyzed by examining stress, strain, displacement, and other relevant data, paying close attention to areas of high stress or deformation. Plots were created.

## CHAPTER FOUR :DESIGN OF THE PROPOSED BED

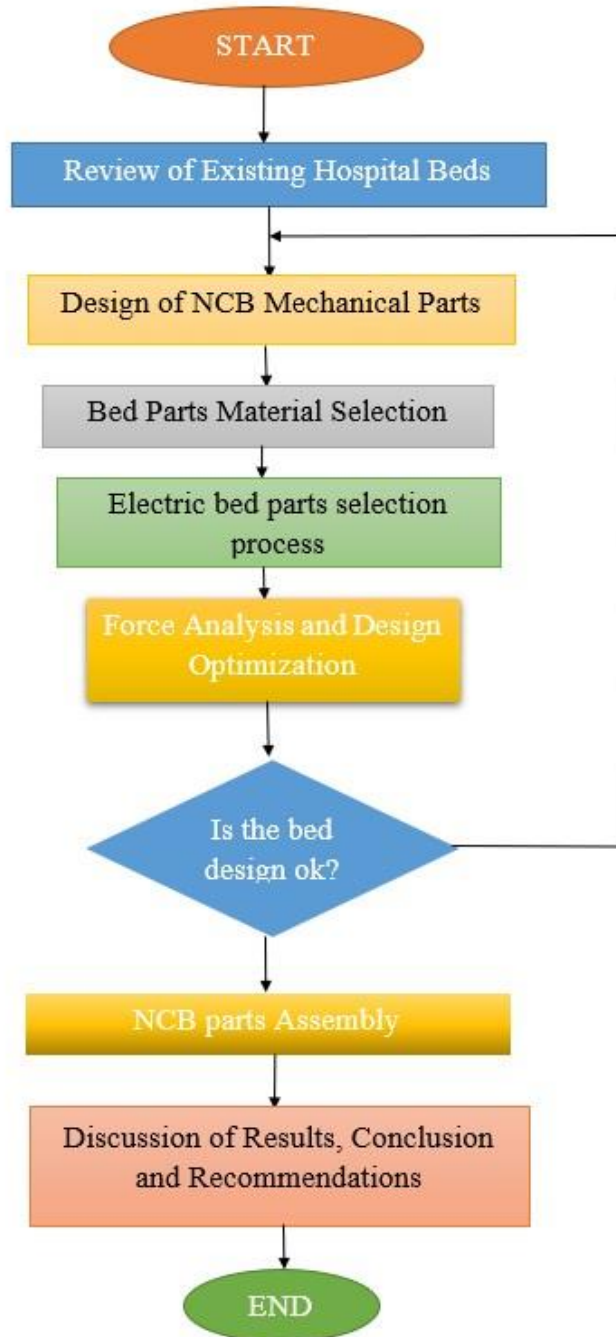
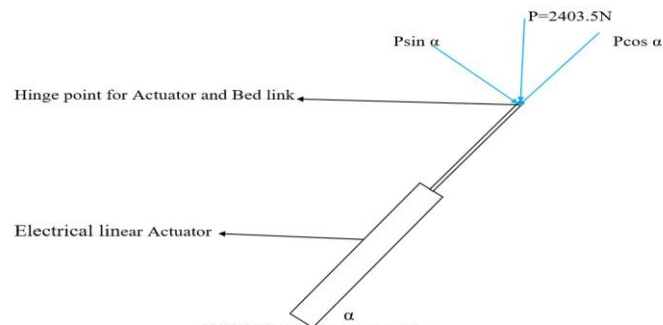

Figure 4.1: Design flow chart for Nursing Care Bed

## 4.1 Design Overview

The model comprised the Top bed frame, two bed link assemblies, eight hinge bolts, a bed base frame, four electric linear actuators, a control panel, and four castor wheels. As compared to existing model with foot operated hydraulic actuated cylinder for height adjustment and hand and foot cranked hydraulic actuated cylinders for head and legs adjustments. Mathematical tools were used to size the NCB mechanical components. Solid Works software was used to design mechanical parts for the nursing care bed. One edge of the part bed profile was sketched, forming a new part of different bed sections. After that, material and dimensions were selected for each element design. Furthermore, a iterative force analysis and design optimization was performed to establish their performance under loading a Then, using the mate command located on the assembly tab of the command manager, two-bed parts were mated simultaneously until the completion of the bed assembly. Similarly, electrical bed parts were selected using Proteus 8 software As Illustrated in 4.1

## 4.2 Actuator Selection



**Figure 4.2: Free body diagram for forces acting on the height adjustment linear actuator**

#### 4.2.1 Mathematical Modelling of Height and Trendelenburg Actuator

Consider a patient of 200 kg as the maximum mass since most patients are between 35 and 150 kg on average. Total weight = maximum patient's weight + weight of Top bed frame + weight of links = 200 + 30 + 15 = 245 kg. Thus, total load = 245 x 9.81 = 2403.5N.

**Table 4. 1: Force height adjustment linear actuator**

No	Angle= $\alpha$ (Degrees)	Pcos $\alpha$ (N)
1	0	2403.5
2	5	2394.4
3	10	2366.9
4	15	2312.6
5	20	2258.6
6	25	2178.3
7	30	2081.5
8	35	1968.8
9	40	1841.8
10	45	1699.3
11	50	1544.9
12	55	1378.6
13	60	1202.8

Consider a free-body force diagram of the actuator a shown in Figure 4.2. From Table4.1 the maximum force is when the angle  $\alpha = 0$  with the corresponding force of 2403.5N. Therefore, the required specification of the electric linear actuator is greater than this force which is  $\{F > 2403.5N\}$ , where F is the linear actuator force rating in newtons. This was selected from the manufacturer's catalogue.

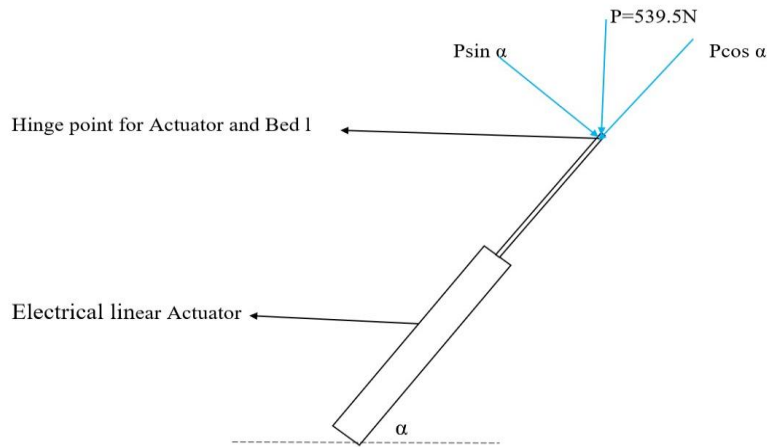

**Figure 4. 3: Free body diagram for forces acting on the head and legs adjustment linear actuators**

**Table 4.2: Forces on head and leg rest linear actuator**

No	Angle= $\alpha$ (Degrees)	$P \cos \alpha$ (N)
1	0	539.55
2	5	537.5
3	10	531.4
4	15	521.2
5	20	507.01
6	25	489
7	30	467.3
8	35	441.9
9	40	413.3
10	45	381.5
11	50	346.8
12	55	309.47
13	60	26

### 4.2.2 Mathematical Modelling of Head and Legs Actuator

For head and leg adjustments, two electric linear drive actuators were utilized for with the same rating; their main components were a motor assembly and a lead screw. Figure 4.3 illustrates the forces acting on the actuator.

**Table 4.3: Top bed frame, link, and base dimensions**

Bed component	Length(mm)	Width(mm)
Top bed frame	2000	880
Bed link	400	407
Base frame	1000	400
Hinge bolt	80mm	M10

The following presumptions served as the basis for the selection: The assumption was made that a patient's upper and lower body portion has a maximum weight of 45 kg each. The head-rest and leg-rest frame weighed 10 kg each. Therefore, the total weight exerted on each headrest and leg-rest actuator was  $45 + 10 = 55\text{kg}$ .

From Table 4.2, the maximum force was when the angle  $\alpha = 0$  with the corresponding force of 539.55N. Therefore, the required specification for the electric linear actuator was greater than this force which was  $\{F > 539.55\text{N}\}$ , where F is the linear actuator force rating in newtons. This was selected from the manufacturer's catalogue.

### 4.3 Design of the Bed Super Structure

The superstructure of the bed comprises the top bed frame, link assembly, Hinge bolts and bed base frame, and their sizes are given in Table 4.3.



**Figure 4.4: Top Bed frame**

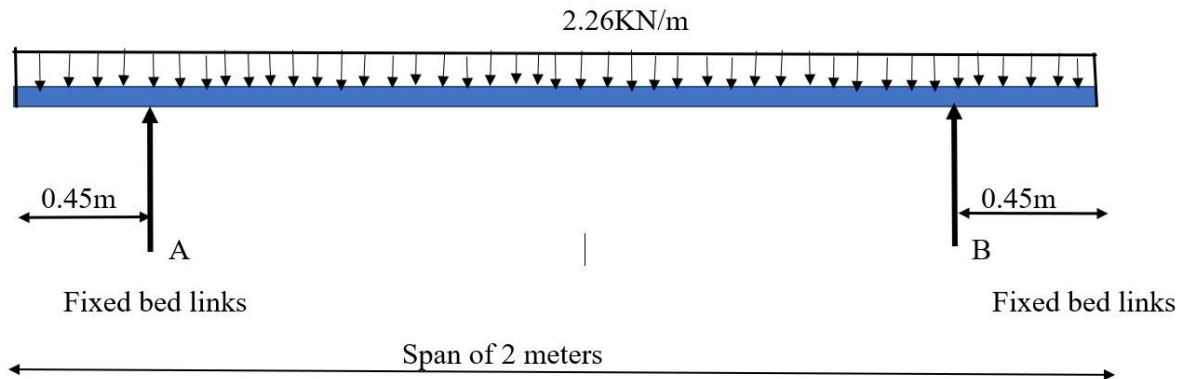

**Figure 4. 5: Free body diagram for NCB Top Frame**

### 4.3.1 Design of Top Bed Frame

Considering the following design parameters: Maximum patient mass = 200kg, mass of top frame = 30kg, The total mass of the top frame and patient = 230kg, Total force =  $230 \times 9.81 = 2260\text{N}$ , Effective span between supports  $L_{\text{eff}} = 2 - 0.9 = 1.1\text{m}$ , length of top bed frame = 2m, supports were fixed at 0.45m from the ends, rectangular hollow section dimensions =  $50 \times 30 \times 3\text{mm}$ , and factor of safety = 1.5.

The CAD drawing of the top bed frame is illustrated in Figure 4.4 and its size is given in Table 4.3.

Considering the top bed frame as a pinned supported beam with a uniformly distributed load UDL( $w$ ) as shown in the free body diagram (Figure 4.5), reactions to support are given by

$$R_A = R_B = \frac{w.l}{2} = \frac{2260 \times 2}{2} = 2260N \quad (4.1)$$

and the maximum bending moment is given by

$$M_{max} = \frac{w \times l_{eff}^2}{8} = \frac{2260 \times 1.1^2}{8} = 341.825N \quad (4.2)$$

The moment of inertia for the rectangular hollow section is given by

$$I = \frac{(bh^3) - (b - 2t^3)(h - 2t)}{12} = \frac{(50.2700 - 44.13824)}{12} = 61812mm^4 \quad (4.3)$$

Also, the section modulus is given by

$$\frac{I}{y} \quad (4.4)$$

where  $y$  is the distance from the neutral axes to the outermost surface,

computed as

$$y = \frac{h}{2} = \frac{30}{2} = \frac{61812}{15} = 4120.8mm^3 \quad (4.5)$$

Thus, maximum bending stress is calculated as

$$\sigma_{max} = \frac{M_{max}}{S} = \frac{341825}{4120.8} \approx 82.95Mpa \quad (4.6)$$

From maximum bending moment of 341.825N.m and maximum bending stress of 82.95Mpa, the maximum bending stress for ASTM-A36 Steel was below the yielding stress of 250Mpa, indicating the size and selection were safe for design.



**Figure 4.6: H Bed link**

**Table 4. 4: Normal and Bending stress**

Angle= $\theta$	$\sigma_N$ (Mpa)	$\sigma_M$ (Mpa)	$\Sigma x = \sigma(N) + \sigma(M)$ (Mpa)
0	0	107.574717	107.54717
5	0.151543209	106.0000	106.15154
10	0.302314814	104.79245	105.0947676
15	0.450308642	102.792453	106.8565586
20	0.59537037	100.0188679	100.6142383
25	0.73549383	96.45283019	97.18832402
30	0.871296296	92.16981132	93.03356045
35	0.998425925	87.1698113	88.16823725
40	1.11882716	81.51698113	82.63580829
45	1.238084198	75.24528302	76.47614722
50	1.333333333	68.41509434	69.67295597
55	1.425925926	61.03396226	62.4598819
60	1.507407407	53.2075474717	54.71495458

### 4.3.2 Design of Link Bed

The patient's weight and bed parts exert force on a link that cause shearing and bending. Considering a square hollow section bed link of 30x30x3mm, with variable angle of inclination

$\theta$ . Figure 4.6 illustrates the H link for the bed model.

The normal stress due to normal force is given by

$$\sigma_N = \frac{N(\theta)}{A} \quad (4.7)$$

Normal stress due to bending is calculated as

$$\sigma_M = \frac{M(\theta)}{W_x} \quad (4.8)$$

$$W_X = \frac{I_X}{y_{max}} \quad (4.9)$$

and  $I_X = \frac{a^4 - (a-2t)^4}{12}$ , where  $I_X$  is the second moment of inertia.

The yield stress for ATSTM-A36 is 250Mpa such that

$$\sigma_y = \frac{250}{1.5} = 166. \quad (4.10)$$

From the above analyses,  $\Sigma x \leq \sigma(y)$ . Therefore, the link is safe for design.



**Figure 4.7: Bed Base Frame**

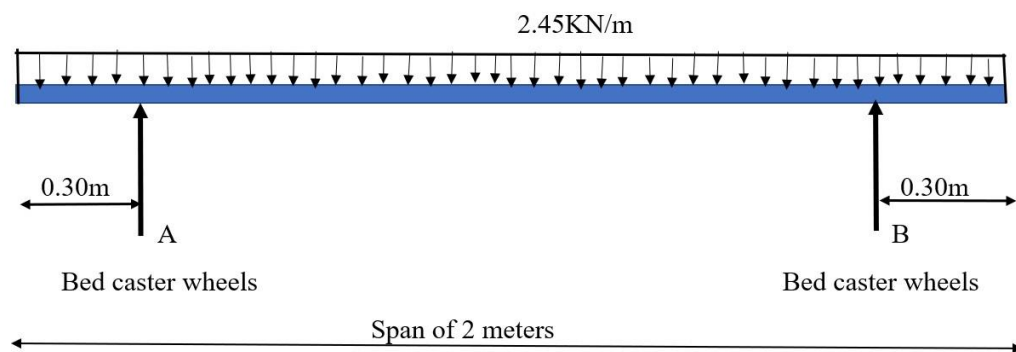

**Figure 4.8: Free body diagram for bed base frame**

### 4.3.3 Design of Bed Base Frame

The CAD drawing of the bed base frame is presented in Figure 4.7. Considering the following design parameters: maximum patient weight = 200kg, mass of top frame = 30kg, weight of links = 20kg, total weight  $25+200 = 250\text{kg}$ , total force  $=250 \times 9.81 = 2452.5\text{N}$ , effective span between supports  $L_{\text{eff}} = 2 - 0.6 = 1.4\text{m}$ , length of top bed frame = 2m, supports were fixed at 0.3m from the ends, rectangular hollow section dimensions = 50x30x3mm, and factor of safety = 1.5. Considering the bed base frame as a pinned

supported beam with uniformly distributed load UDL ( $w$ ) as shown in the free body diagram Figure 4.8, reactions at supports are given by

$$R_A = R_B = \frac{w.l}{2} = \frac{2452 \times 2}{2} = 2450N \quad (4.11)$$

The maximum bending moment is given by

$$M_{max} = \frac{w.l_{eff}^2}{8} = \frac{2452 \times 1.1^2}{8} = 600.25N \quad (4.12)$$

For rectangular hollow section  $b=50\text{mm}$ ,  $h=30\text{mm}$  and thickness  $t=3\text{mm}$ ;

the moment of inertia for the rectangular hollow section is given by

$$I = \frac{(bh^3) - (b - 2t^3).(h - 2t)}{12} = \frac{(50.2700 - 44.13824)}{12} = 61812\text{mm}^4 \quad (4.13)$$

Also, the sectional modulus is calculated as

$$S = \frac{I}{y} \quad (4.14)$$

where  $y$  is the distance from the neutral axes to the outermost surface given as

$$y = \frac{h}{2} = \frac{30}{2} \quad (4.15)$$

such that

$$S = \frac{61812}{15} = 4120.8\text{mm}^3 \quad (4.16)$$

Maximum bending stress is computed as

$$\sigma_{max} = \frac{M_{max}}{S} = \frac{600250}{4120.8} \approx 145.7Mpa \quad (4.17)$$

Table 4.4 presents results for normal and bending stresses at various actuator angles. From the maximum bending moment of 600.25N.m and maximum bending stress of 145.7Mpa, the maximum bending stress for ASTM-A 36 steel was below the yielding stress of 250MPa, indicating the size and selection were safe for design.

#### 4.3.4 Design of Hinge Bolts

The hinge bolts for the nursing care bed model were selected from chromium-vanadium steel AISI 6170 of the following specifications: Yield strength  $S_y = 620Mpa$ , Ultimate tensile strength  $S_u = 940Mpa$ , shear force ( $V$ ) = 2403.5N, and a factor of safety ( $F$ ) = 3.

Allowable shear stress is  $\tau_a = \frac{S_s}{F}$ , but  $S_s = 0.6S_u$ . Thus,

$$\tau_a = \frac{0.6S_u}{F} = \frac{564}{3} = 188Mpa \quad (4.18)$$

Required shear Area

$$A_s = \frac{V}{\tau_a} = \frac{2403.5}{188 \times 10^6} = 1.28 \times 10^{-5} m^2 \quad (4.19)$$

For circular cross-sections,  $A_s = \frac{\pi d^2}{4}$ ,  $d = \sqrt{\frac{4A_s}{\pi}} = \sqrt{\frac{4 \times 128}{\pi}} = 4.04mm$ .

But considering other components, we selected a diameter of 10mm for hinge bolts.



**Figure 4.9: Caster Wheel**

#### **4.3.5 Design of Caster Wheels**

Consider the following parameters: patient's maximum weight = 200kg, top bed frame weight = 30kg, bed link weight = 15 kg, bed base frame weight = 20kg, and the factor of safety for the caster wheel = 1.5,

Total bed dead weight is  $265 \approx 270kg$  such that the total dead force exerted on the caster wheels is  $270 \times 9.81 = 2746.8KN$ .

Let maximum additional load =  $15 \times 9.81 = 147.15$ , from  $T = \frac{E+Z}{n}S$ , where T = required load capacity per caster wheel, E = dead weight of hospital bed, Z = maximum additional weight, n = number of caster wheels, and S = factor of safety for caster wheel. Therefore

$$T = \left( \frac{2746.8 + 147.14}{4} \right) \cdot 1.5 = 1085.2N \quad (4.20)$$

Thus, the weight on each caster wheel is given by  $\frac{1085.2}{9.81} = 110.6kg$ . Therefore, each caster wheel carries a load of 1085.2N approximately to 110.6kg. Used a manufacturer's catalogue to select the appropriate type and size and the designed caster wheel is presented in Figure 4.9.



**Figure 4.10: Block Control Circuit Diagram for Nursing Care Bed**

**Table 4.5: Electrical parts for Nursing Care Bed**

No	Electrical component	Rating	Quantity
1	Capacitor( $C_1$ )	220mF	3
2	Resistance(R)	10 $\Omega$	3
3	Fuse	2A	2
3	Transformer	240-12V	1
5	Diode		4
6	SPST Switch		8
7	Connecting cables		
8	Relay	12DCV8A2W	8
9	Rectifier	20A	1
10	Regulator	LM7812	1

#### 4.4 Development of Control Circuit

Several electrical components, such as resistors, transformers, relays, diodes, regulators, switches and capacitors, were assembled to develop a circuit control for a nursing care bed, as illustrated in Figure 4.10 and Figure 4.11. Moreover, the specifications and ratings of the circuit components are provided in Table 4.5.

#### **4.4.1 Electric Components for Automating the Nursing Care Bed**

The electric circuit was developed to control the height adjustment, head adjustment, leg adjustments, and Trendelenburg adjustment positions for the Nursing care bed. As described in Table 4.5, different components were incorporated to achieve the intended objective. The selection of electrical parts for a nursing care bed involved several considerations to ensure safety, reliability, and compatibility with the bed's electrical system.

Capacitors were selected based on capacitance (in this case, 220 micro farads) which determines the amount of charge it can store and release. Other factors include voltage rating (should exceed the maximum voltage it will encounter) and size (fit within the space constraints). Similarly, resistors were selected based on their resistance value (in this case, 10 ohms) which determines the current flow through the circuit and dissipates power as heat. Other considerations include power rating (should handle the expected wattage without overheating).

Thirdly, fuses protect circuits from over-current situations. They were selected based on their current rating (2amps) which should be slightly higher than the maximum expected current draw of the circuit. Voltage rating and fuse type (fast-blow, slow-blow) were also considered. Furthermore, Transformers step-down voltages were needed. Selection involves primary and secondary voltage ratings (240V primary, 12V secondary), power rating (VA or watts), and physical size compatibility. Diodes allow current to flow in one direction only. The selection was based on current and voltage ratings, forward voltage

drops, and switching speed if applicable. Single-Pole Single-Throw (SPST) switches are simple on-off switches. The selection involved current rating, voltage rating, type of actuator (toggle, rocker, etc.), and mounting type (panel mount, PCB mount). Cables were selected based on current carrying capacity (ampacity), voltage rating, insulation type (to prevent short circuits), and length suitable for the installation.

Additionally, relays are electromagnetic switches used to control higher currents with a lower current control signal. The selection criteria were based on coil voltage (12V DC), contact current rating (8A), contact configuration (SPST, SPDT), and type (mechanical, solid state). Rectifiers convert AC to DC. Criteria included current rating (20A), voltage rating, forward voltage drop, and package type (bridge rectifier, individual diodes). Voltage regulators maintain a constant output voltage. Criteria included input voltage range, output voltage (12V for LM7812), current capability, dropout voltage, and thermal considerations.

When selecting these components, it was crucial to refer to the bed's electrical specifications and operational requirements to ensure all parts are compatible, safe, and reliable for the intended application in a hospital environment. The circuit was designed using Proteus 8 software.

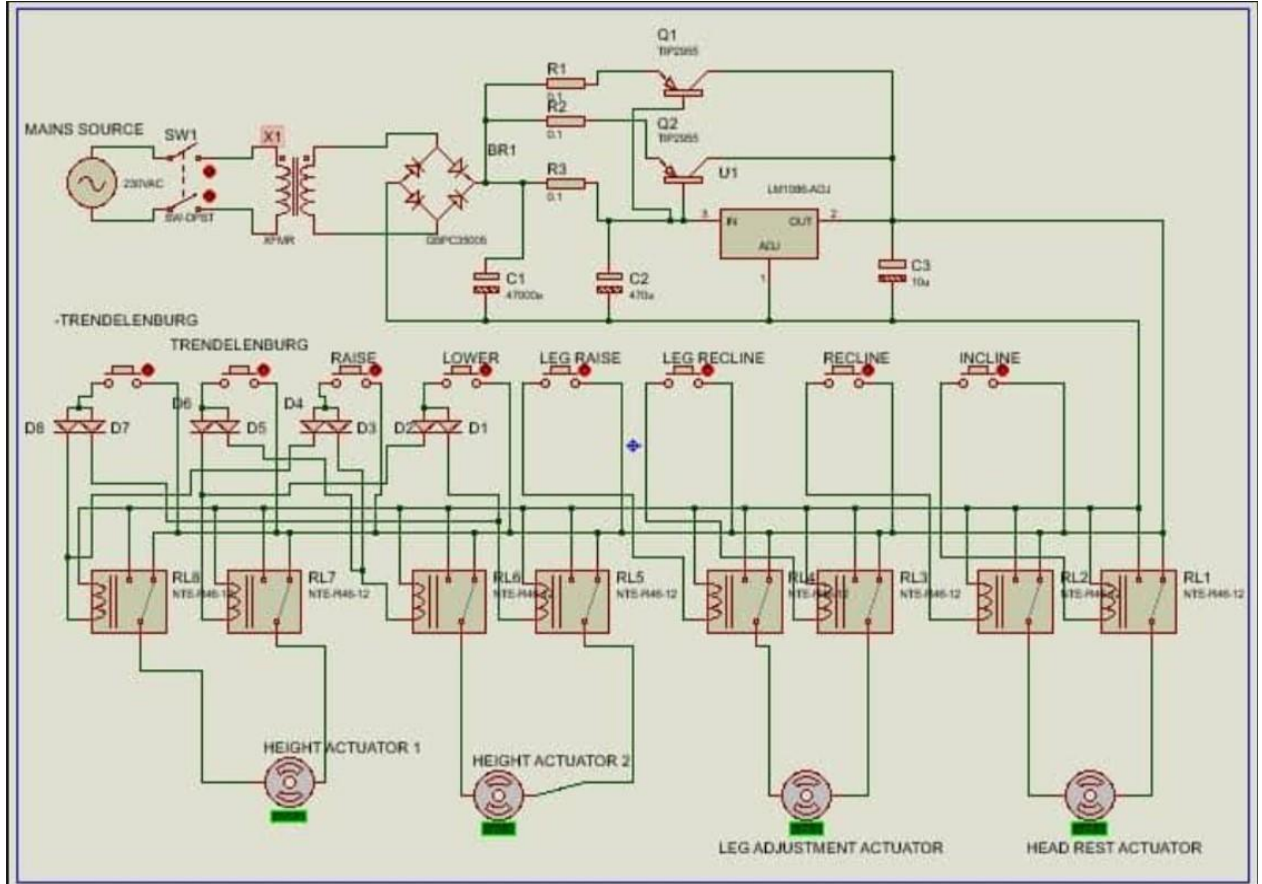

**Figure 4.11: Electric control circuit for Nursing care bed**

#### 4.4.2 Control Panel

Figure 4.11 illustrates the developed control panel for the bed. It consists of eight buttons that can be used to adjust the bed to a suitable posture. These buttons include Trendelenburg, reverse Trendelenburg, head adjustment, leg adjustment, and height adjustment.

#### 4.4.3 Control System Design

As illustrated in Figure 4.11, the electronic and control system design for a Nursing care bed involves a comprehensive setup to ensure precise control and reliable operation of the

bed's various movements. The system starts with a main power source that provides 240 VAC, which is connected to a transformer (X1) to step down the voltage to a suitable level for the electronic components.

A rectifier bridge (BR1) converted the AC voltage to DC, which was then smoothed by capacitors (C1 and C3) to reduce ripple and provide a stable DC output. A voltage regulator (U1, LM338-ADJ) ensured the output voltage was consistent and within the required range for the circuit. The control system utilized relays (RL1 to RL8) to switch the actuators on and off, enabling various bed movements. These relays were activated by corresponding switches that the user could control.

The switches (D1 to D8) were configured to manage specific functions such as raising or lowering the bed, adjusting the Trendelenburg position, and reclining the head and leg sections. Each relay was connected to an actuator responsible for a specific movement: height adjustment actuators (1 and 2) control the overall elevation of the bed, the leg adjustment actuator manages the leg raise and recline functions, and the headrest actuator adjusts the head section.

The diodes (D1 to D4) are protected against voltage spikes that can occur when the relays switch, ensuring the circuit's longevity and reliability. Resistors (R1 to R3) were used to limit current and ensure the correct operating conditions for transistors (Q1 and Q2, TIP2955) that are part of the control circuitry. These transistors acted as switches that were controlled by the relay coils, further enhancing the reliability and responsiveness of the system. Overall, the design integrates power management, signal processing, and

actuator control, creating a robust and flexible system capable of adjusting the bed's position as needed for patient comfort and care. The combination of relays, switches, diodes, resistors, and transistors, along with careful power regulation, ensured that the nursing care bed operated smoothly and reliably, providing critical functionality in medical environments.

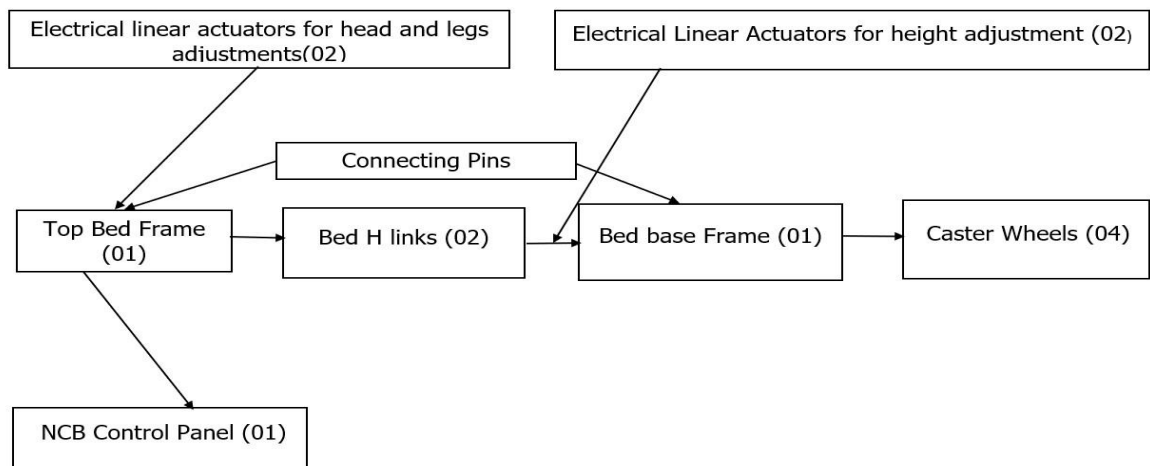

**Figure 4.12: Block Diagram for design Table**

**Table 4.6: Nursing care bed part.**

No	Part description
1	Head rest board
2	Bed Headrest frame SHS 30X30X3
3	Top Frame 50x30x3
4	Control Panel
5	Base Frame RHS 50X30X3
6	Caster Wheel x4 with brake system
7	Movable H Link SHS 30x30x3
8	back Rest Board

#### 4.5 Assembled Bed System

The assembled bed system consisted of the top bed frame, on which the headrest and leg rest are hinged; they are adjusted using linear actuator drives. The top bed frame is connected to the link assembly by hinge bolts, on which two linear actuators are connected for height and Trendelenburg adjustments. Additionally, the Hinge bolts join the bed link assembly to the bed base frame, and lastly, the caster wheels are mounted to the bed base frame for easy transportation as illustrated in figure 4.12 block diagram



**Figure 4. 13: Nursing care bed**

The mechanical and electrical bed parts were assembled and the final model was attained as shown in Figure 4.13 and nomenclature in Table 4.6. Moreover, the detailed drawings are presented in Appendix A.

#### 4.6 Performance Comparison Table

**Table 4.7: Hospital Bed performance Comparison Table**

<b>Bed parameters</b>	<b>Manual Hydraulic bed</b>	<b>Nursing care bed</b>
Maintenance cost	High	Low
Mode of operation	Manually	Electric
Type of Actuation System	Four Hydraulic Cylinder actuators	Four linear Electric actuators

The performance of a manual hydraulic hospital bed with four hydraulic cylinder actuators and a nursing care bed with electric linear actuators is compared in Table 4.7. From the table, manual hydraulic hospital beds have a high maintenance cost linked to routine changing of oil and changing of oil seals, as in contrast to nursing care beds that require no maintenance. Moreover, a nursing care bed uses an electronic linear actuator with a place button for actuation, but manual hydraulic beds are operated manually with a foot pedal and require some energy. The difference is that one is hydraulic actuation and another is an electric linear actuator.

## **CHAPTER FIVE:FORCE ANALYSIS AND DESIGN OPTIMIZATION**

The model was analyzed using the Solid Works software program. First, the right dimensions and materials were selected for each component, including the Base bed frame, Bed link assembly, Hinge bolts, Top bed frame, and electric linear actuator, to generate 3D models of each, as discussed in the previous chapter. In this chapter, the von Mises stress analysis is done for each mechanical component to optimize and validate the proposed bed.

### **5.1 Procedure for Force Analysis on Nursing Care Bed**

To simulate a mechanical component for a nursing care bed in SolidWorks, the process started by creating or importing the 3D model of the component and simplifying it to remove unnecessary details. Then, open SolidWorks Simulation from the Simulation tab or add in to create a new study by selecting the appropriate type of analysis, such as static, dynamic, thermal, or frequency analysis. It followed the assignment of material properties to the component, including elastic modulus, Poisson's ratio, and density. Furthermore, define the boundary conditions by applying fixtures to constrain the component and specifying the loads, such as forces, pressures, or thermal effects. Then came the generation of a finite element mesh to divide the model into smaller elements and refine the mesh in critical areas for greater accuracy. A simulation was then run to solve the governing equations based on the defined conditions. When the simulation was complete, the results were analyzed by examining stress, strain, displacement, and other relevant data, paying close attention to areas of high stress or deformation. Plots were created.

**Table 5. 1: Study properties for the mechanical part of the bed.**

1	Analysis type	Static
2	Mesh type	solid mesh
3	Thermal effect	on
4	Thermal option	include temperature loads
5	Zero strain temperature	298 Kelvin
6	Solver type	Automatic
7	incompatible bonding options	Automatic

### **5.1.1 Study Properties of Nursing Care Bed Super structure**

Table 5.1 outlines the properties and settings for a mechanical study conducted on parts of the bed. The analysis type specified is static, indicating that the part was analyzed under steady-state conditions without considering dynamic effects. The part was detached using a solid mesh, which ensured that the entire volume of the component was considered in the numerical analysis. Additionally, thermal effects were included in this study, meaning that temperature variations and their impact on the part were accounted for. Specifically, the thermal option to include temperature loads was enabled, allowing for the consideration of thermal gradients or specific temperature conditions applied to the part. The zero-strain temperature was set at 298 Kelvin, serving as the reference temperature at which the material is assumed to have no thermal strain. Finally, the solver type was set to automatic, which allowed the software to select the most appropriate solver based on the characteristics of the problem, optimizing the analysis process. Additionally, the incompatible bonding options were also set to automatic, ensuring that any mesh interfaces that were not perfectly compatible were handled automatically by the software, facilitating a more seamless and accurate analysis. This comprehensive setup ensured that

the mechanical and thermal behaviours of the bed part were thoroughly evaluated under the specified conditions.

**Table 5.2: Mesh information for top frame**

1	Mesh type	Solid Mesh
2	Mesher used	Blended curvature -based mesh
3	Jacobian points for high-quality mesh	16 points
4	Maximum element size	72.8851mm
5	Minimum element size	3.6442mm
6	Mesh quality	high

**Table 5. 3: Mesh information for Base Frame**

1	Mesh type	Solid Mesh
2	Mesher used	Blended curvature -based mesh
3	Jacobian points for high-quality mesh	16 points
4	Maximum element size	59.7472mm
5	Minimum element size	2.98736mm
6	Mesh quality	high

### **5.1.2 Meshing information for Nursing Care bed Super structure**

Table 5.2 details key information regarding the mesh setup for the Top Frame. The mesh type utilized is a Solid Mesh, which is appropriate for detailed 3D structural analysis. The meshing process was conducted using a blended curvature-based mesh method, known for its capability to adapt to complex geometries by varying element sizes based on curvature, ensuring high dedication in critical areas while maintaining efficiency. To ensure high-quality mesh, Jacobian points were set to 16, which enhances the accuracy of the elements' shape and distortion assessment. The mesh size ranges from a maximum

element size of 72.8851 mm to a minimum element size of 3.6442 mm, allowing for a balance between computational efficiency and detail resolution. Overall, the mesh quality is deemed high, indicating that the mesh elements were well-formed and suitable for precise finite element analysis.

Table 5.3 provides detailed information about the mesh configuration for the Base Frame. The mesh type selected was a Solid Mesh, which was suitable for detailed three-dimensional structural analysis. The meshing process employed a blended curvature-based mesh technique, which adapts element sizes based on the curvature of the model, ensuring that areas with complex geometry receive finer mesh elements for greater accuracy. To maintain a high-quality mesh, 16 Jacobian points were utilized. This enhances the evaluation of the elements' shape and deformation, ensuring they remain within acceptable limits. The element size varies from a maximum of 59.7472 mm to a minimum of 2.98736 mm. This range ensured a good balance between computational efficiency and the level of detail required for accurate analysis. Overall, the mesh quality was classified as high, indicating that the mesh elements were well-formed and suitable for precise finite element analysis.

**Table 5. 4: Mesh Details for Top Frame**

1	Total Nodes	849943
2	Total Elements	424325
3	Maximum Aspect Ratio	29.779
4	%of elements with aspect ratio<3	94.4
5	Percentage of elements with aspect ratio> 10	0.00141
6	Percentage of distorted elements	0
7	Time to complete mesh (hh, mm, ss)	00.01.13

Table 5.4 outlines the detailed mesh characteristics for the Top Frame. The mesh consists of a total of 849,943 nodes and 424,325 elements, indicating a finely detailed mesh suitable for complex structural analysis. The maximum aspect ratio of the elements was 29.779, which, while relatively high, was likely limited to a small number of elements in less critical regions. A significant 94.4% of the elements had an aspect ratio of less than 3, suggesting that the majority of the elements were of good quality, with nearly ideal shapes that provided accurate analysis results. Only a negligible 0.00141 % of elements had an aspect ratio greater than 10, implying that poorly shaped elements were extremely rare. Additionally, there are no distorted elements present in the mesh, indicating a high level of mesh integrity and reliability. The entire meshing process was completed efficiently in 1 minute and 13 seconds, demonstrating both the effectiveness of the meshing algorithm and the computational resources used. Overall, the mesh quality and setup for the Top Frame appear to be excellent, providing a robust foundation for subsequent analysis.

**Table 5.5: Mesh details for Base Frame**

1	Total Nodes	679559
2	Total Elements	337561
3	Maximum Aspect Ratio	9.1341
4	%of elements with aspect ratio<3	95.1
5	Percentage of elements with aspect ratio> 10	0
6	Percentage of distorted elements	0
7	Time to complete mesh (hh, mm, ss)	00.01.44

Table 5.5 presents the mesh details for the Base Frame, highlighting its structure and quality. The mesh is composed of 679,559 nodes and 337,561 elements, indicating a

comprehensive and detailed representation of the Base Frame. The maximum aspect ratio of the elements was 9.1341, which was within acceptable limits for ensuring good mesh quality and accuracy in the analysis. A high percentage, 95.1%, of the elements had an aspect ratio of less than 3, signifying that the majority of the elements are well-shaped and ideal for precise finite element analysis. Notably, there were no elements with an aspect ratio greater than 10, and there were also no distorted elements, indicating an excellent overall mesh quality with reliable element shapes. The meshing process for the Base Frame was completed in 1 minute and 44 seconds, demonstrating efficiency and the effective use of computational resources. Overall, the mesh for the Base Frame is of high quality, with a majority of elements exhibiting favourable aspect ratios and no distortion, providing a solid basis for accurate and reliable structural analysis.

**Table 5. 6: Material properties for ASTM 36A material**

No	Material property	Equivalent value
1	Model type	Linear elastic isotropic
2	Default failure Criterion	Max von misses stress
3	Yield strength	$2.5 \times 10^8 \text{N/m}^2$
4	Tensile strength	$4.0 \times 10^8 \text{N/m}^2$
5	Elastic modulus	$2.0 \times 10^{11} \text{N/m}^2$
6	passion's ratio	0.26
7	Mass density	$7850 \text{kg/m}^3$
8	Shear modulus	$7.93 \times 10^{10} \text{N/m}^2$

### 5.1.3 Material Properties of ASTM A36 Steel

Table 5.6 provides the material properties of ASTM A36 steel, detailing its mechanical and physical characteristics. The material is modelled as linear elastic isotropic, meaning

it has uniform properties in all directions and deforms linearly under applied loads. The default failure criterion used was the maximum von Mises stress, which is a common approach for determining the onset of yielding in ductile materials. The yield strength of ASTM A36 steel is  $2.5 \times 10^8 \text{ N/m}^2$ , indicating the stress at which the material begins to deform plastically.  $4.0 \times 10^8 \text{ N/m}^2$  is its tensile strength, which is the highest stress the material can bear before breaking when it is stretched or pulled. The elastic modulus, a measure of the material's stiffness, is  $2.0 \times 10^{11}$  Poisson's ratio, which expresses the relationship between transverse and axial strain, is 0.26 for this material. Its mass density is  $7850 \text{ kg/m}^3$ , indicating the material's mass per unit volume. The shear modulus, which measures the material's response to shear stress, is  $7.93 \times 10^{10} \text{ N/m}$ . These properties make ASTM A36 steel suitable for a wide range of structural applications due to its strength, stiffness, and reliability.

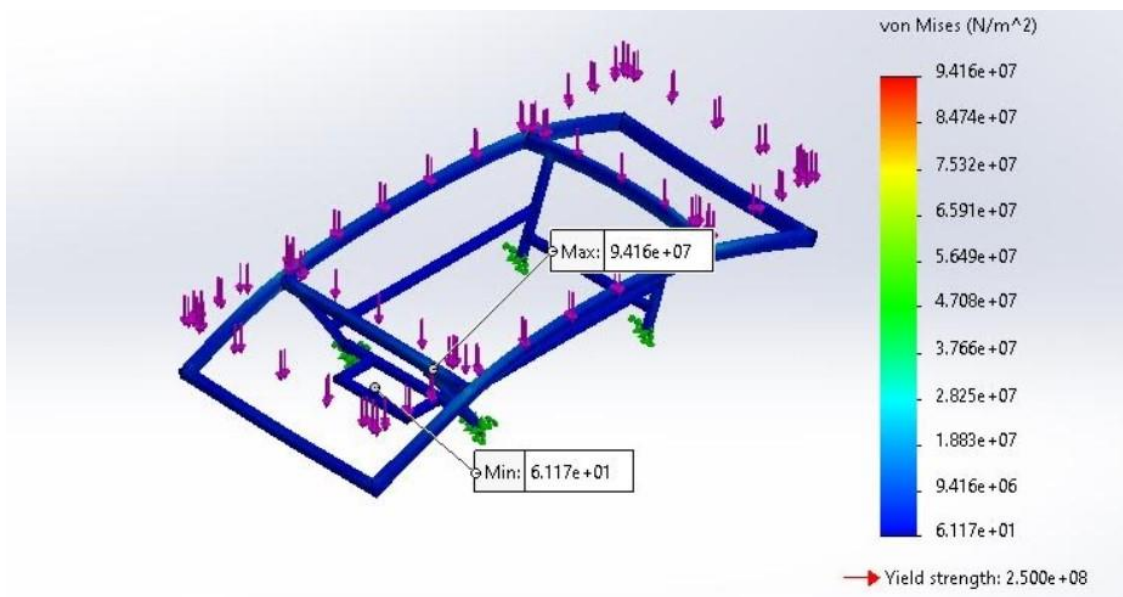
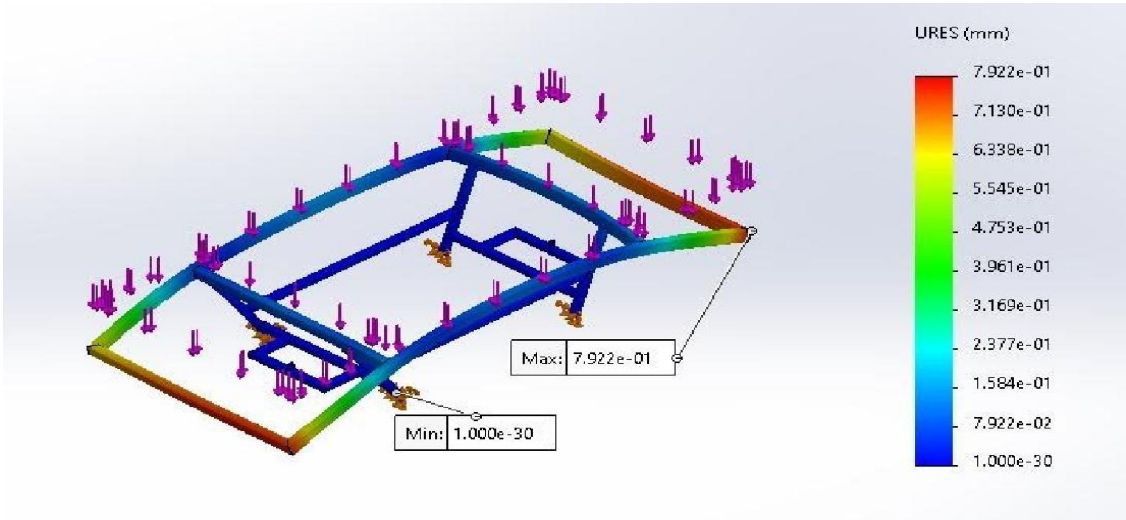

**Figure 5. 1: Stress plot for top bed frame**

## 5.2 Force Analysis Results and Discussions

### 5.2.1 Force Analysis Results for Top Bed Frame

Figure 5.1 illustrates the von Mises stress distribution on the top bed frame of a nursing care bed. The stress plot provided for the top bed frame revealed crucial insights into the structural performance under applied loads. The von Mises stress distribution, represented by the colour scale, indicated that the maximum stress experienced by the frame was  $9.416 \times 10^7 \text{N/m}^2$ , which was significantly below the yield strength of the material  $2.50 \times 10^8 \text{N/m}^2$ . This suggests that the frame was designed to withstand the applied loads without yielding. The stress was most concentrated in specific regions where the load application, depicted by the purple arrows, was most intense, highlighting critical points that required further examination to ensure structural integrity. In contrast, areas with minimal stress, shown in blue, experienced very low stress, indicating regions with less structural demand. Overall, the stress analysis confirmed that the frame can safely endure the operational loads.



**Figure 5. 2: Displacement plot for Top Bed Frame**

Figure 5.2 illustrates the displacement distribution on the top bed frame of a nursing care bed, which visualizes the deformation of the structure under applied loads. The plot employs a colour gradient to represent the magnitude of displacement at various points on the frame, ranging from minimal to maximal values. The colour scale on the right ranges from blue (representing minimal displacement) to red (representing maximal displacement). Intermediate colours (green, yellow, etc.) indicate varying degrees of displacement. This helps in quickly identifying areas of the structure that are experiencing different magnitudes of displacement. The maximum displacement value was noted as (approximately 0.7922 mm), while the minimum displacement is  $1.00 \times 10^{-30} \text{ mm}$  (essentially zero). These values highlight the range of displacements across the frame, showing where the most and least deformations occur. Additionally, the purple arrows indicate the direction and points of applied loads on the frame. The frame was subjected to these loads, which caused the observed displacements. Understanding these conditions is crucial for interpreting the displacement results accurately.

Furthermore, the frame's response to the applied loads is depicted through the varying displacement magnitudes. Areas with higher displacement (towards the red end of the spectrum) may be critical regions that need further analysis or reinforcement, while areas with minimal displacement (towards the blue end) are less affected by the loads. This displacement plot is an essential tool for engineers to assess the structural integrity and performance of the Top Bed Frame. By identifying areas of significant deformation, engineers can make informed decisions on design modifications, material selection, and overall structural improvements to ensure safety and reliability.

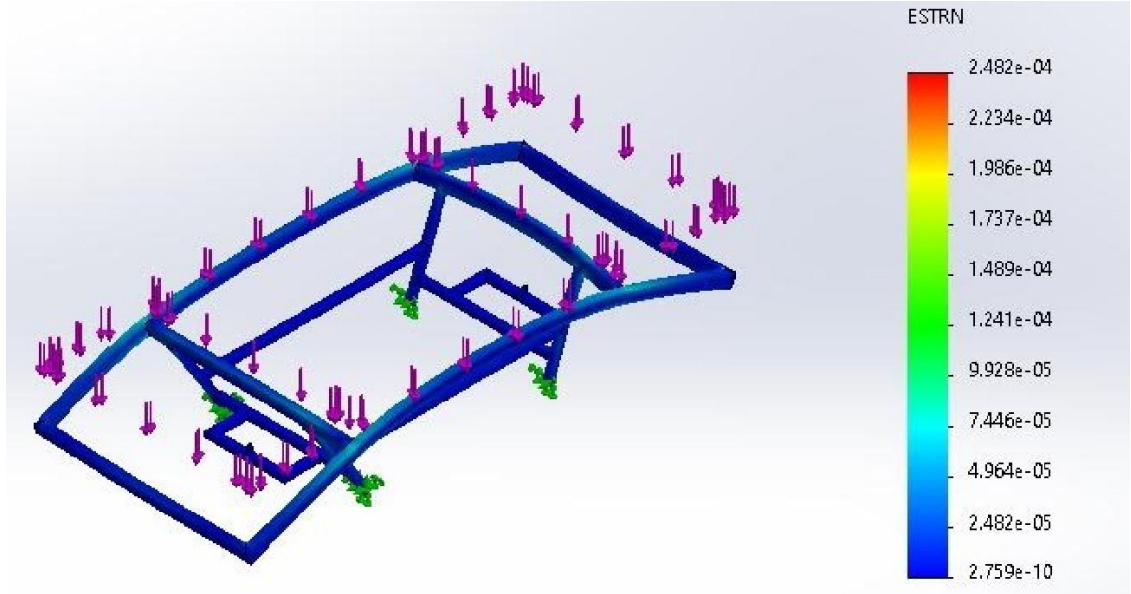

**Figure 5. 3: Strain plot for top bed frame**

Figure 5.3 illustrates the strain distribution on the top bed frame of a nursing care bed. The colour gradient, ranging from blue to red, represents the magnitude of strain, with blue indicating the lowest strain and red indicating the highest strain. The specific strain values are shown on the colour scale to the right, ranging from approximately,  $2.759 \times 10^{-10}$ , to  $2.482 \times 10^{-4}$ . Purple arrows represent the applied loads on the frame, while the green symbols denote the boundary conditions or constraints. The plot provides insight into how the frame deforms at different locations, highlighting areas of potential concern where strain concentrations occur, which may indicate regions prone to failure or requiring reinforcement. This visualization is crucial for engineers to assess the structural performance and ensure the frame's reliability and safety.

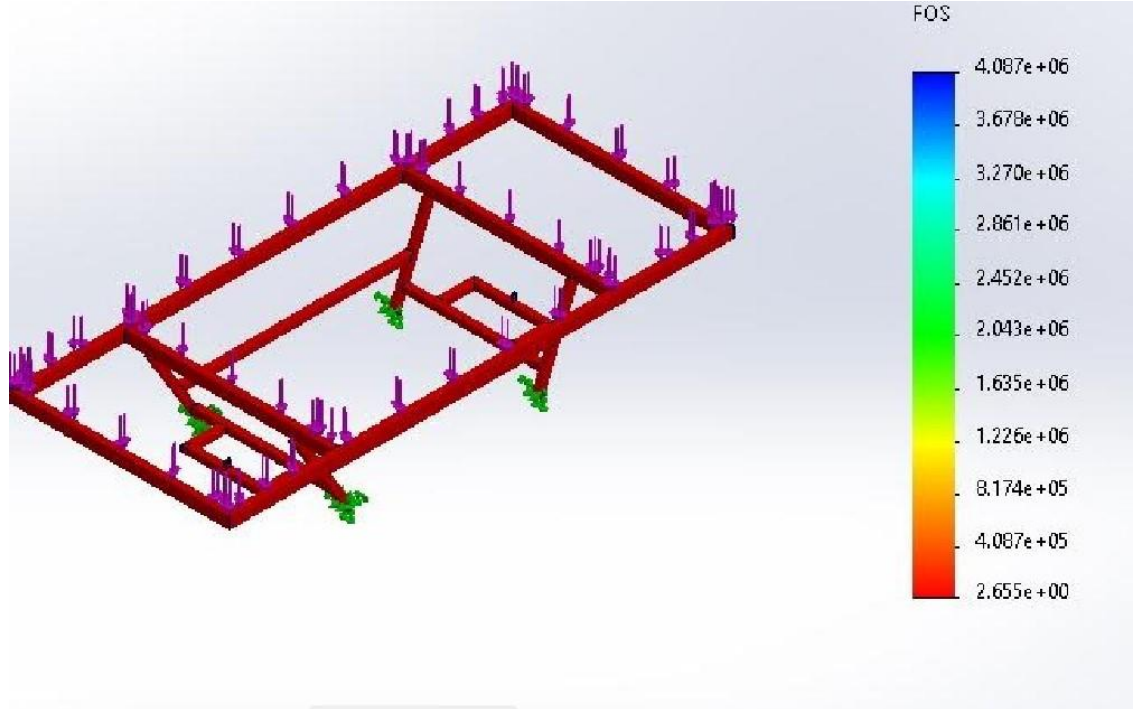

**Figure 5.4: Factor of safety plot for top bed frame**

Figure 5.4 illustrates the factor of safety for the top bed frame of a nursing care bed. The colour gradient, from red to blue, indicates the FOS values across different parts of the frame, with red areas having lower FOS and blue areas having higher FOS. The FOS values range from approximately 2.655 (indicating regions with the lowest safety margins) to  $4.087 \times 10^6$  (indicating regions with the highest safety margins). The purple arrows represent the applied loads, and the green symbols denote the boundary conditions or constraints. Areas with lower FOS values (red and yellow) are of particular interest, as they are more likely to be critical under loading conditions, potentially requiring design improvements or reinforcement to ensure overall structural safety and reliability. This plot is essential for engineers to identify weak points in the design and to take necessary actions to enhance the frame's performance and durability.

### 5.2.2 Force Analysis Results for H Link

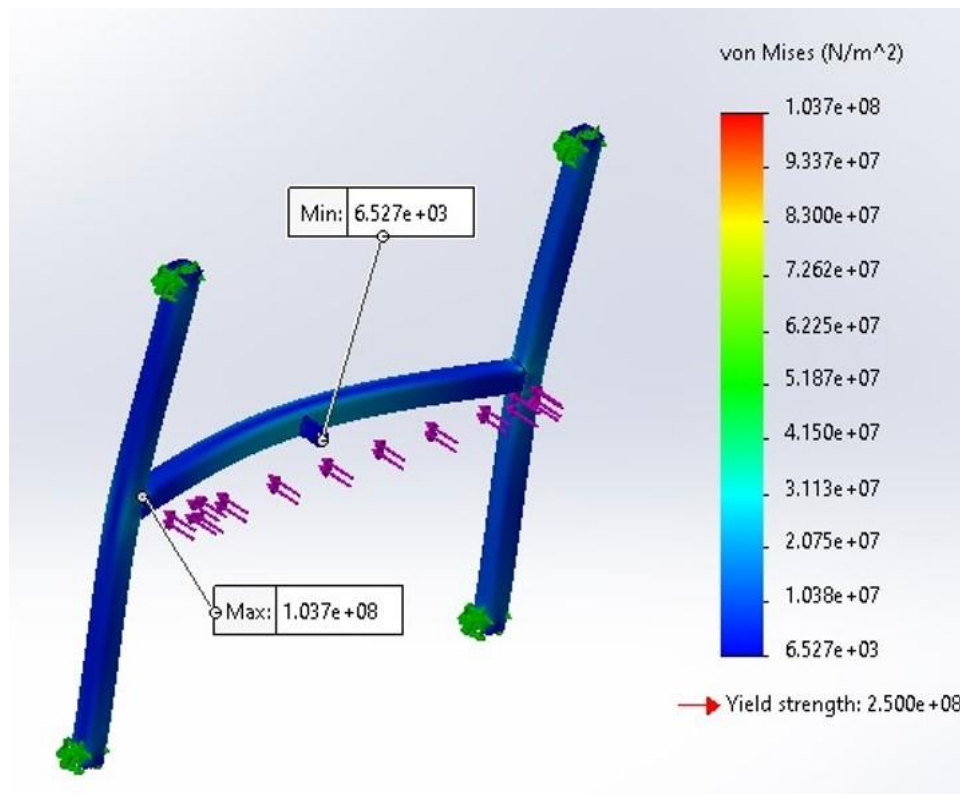

**Figure 5.5: Stress plot for H link**

Figure 5.5 illustrates the von Mises stress distribution on the H link of a Nursing care bed. The maximum stress observed was  $1.07 \times 10^8 \text{ N/m}^2$ , less than half of the material's yield strength of  $2.5 \times 10^8 \text{ N/m}^2$ . This indicated that the bed link was within safe limits under the given loading conditions. The high-stress regions, highlighted in red and orange on the colour scale, are located around the central area where loads are applied, as shown by the purple arrows. These areas should be closely monitored and potentially reinforced to ensure long-term durability and reliability. Conversely, the minimum stress recorded was  $6.527 \times 10^3 \text{ N/m}^2$ , found in regions marked in dark blue, signifying areas with minimal structural load.

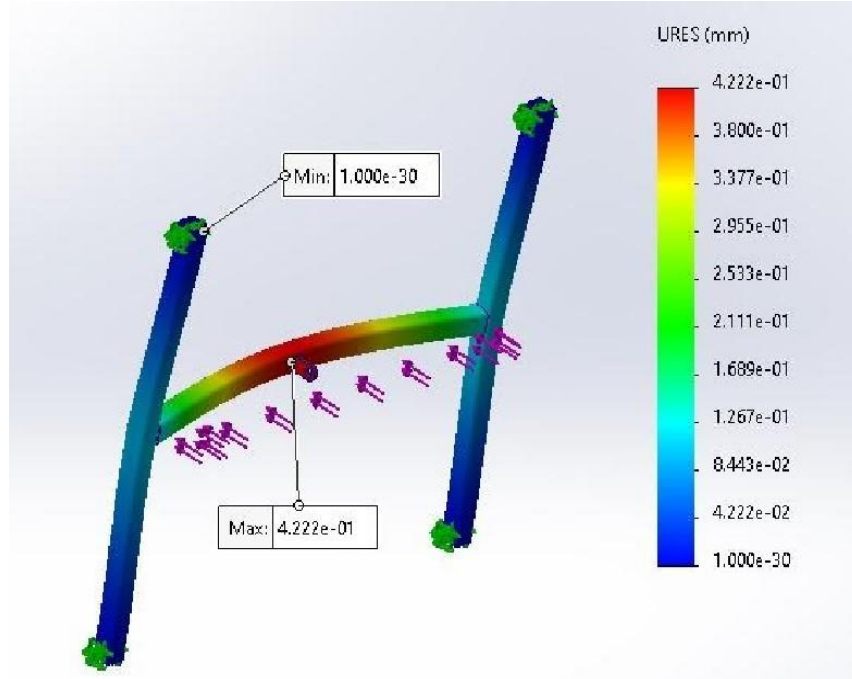

**Figure 5.6: Displacement plot for bed link**

Figure 5.6 illustrates the displacement distribution on the H link of the Nursing care bed. The part is colour-coded according to the magnitude of displacement, with the colour scale on the right indicating values in millimeters (mm). The displacement ranges from a minimum value close to zero ( $1.000 \times 10^{-30}$ ) mm to a maximum value of approximately 0.4222 mm. The maximum displacement occurs in the central part of the link, highlighted in red, while the minimum displacement occurs at the ends, which are likely fixed or constrained. The purple arrows represent the applied loads, and the green markers indicate boundary conditions or fixed supports. This visualization helps in identifying the regions of maximum deformation and understanding the structural response of the part under the given loading conditions.

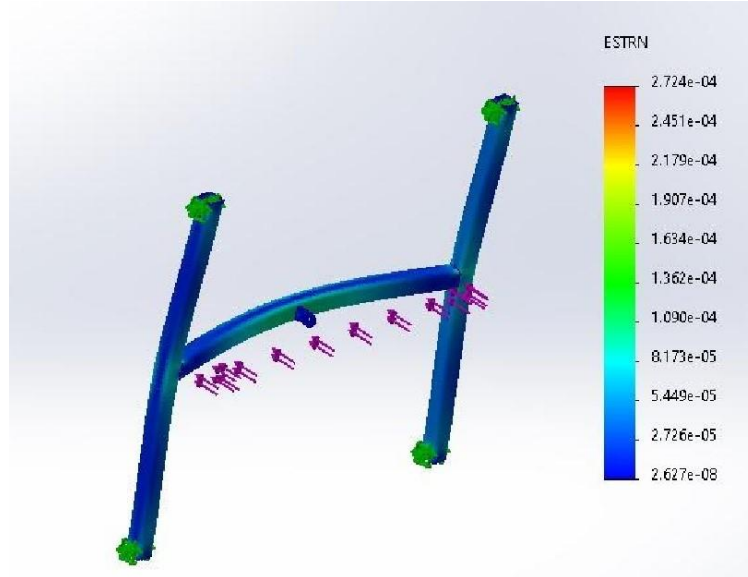

**Figure 5.7: Strain plot for H link**

Figure 5.7 illustrates the strain distribution on the H link of a nursing care bed. It depicts the strain distribution for the Bed Link under applied loads. The colour gradient, ranging from blue to red, represents the magnitude of strain, with blue indicating the lowest strain and red indicating the highest strain. The strain values range from approximately  $2.627 \times 10^{-8}$  to  $2.724 \times 10^{-4}$ , as shown on the colour scale to the right. Purple arrows represent the applied loads on the bed link, while green symbols denote the boundary conditions or constraints. The plot highlights areas of varying strain intensities, with higher strain regions (yellow and red) suggesting potential stress concentrations that might require attention to avoid material failure. This visualization helps engineers assess the structural integrity of the bed link, ensuring it can withstand operational loads without significant deformation or failure.

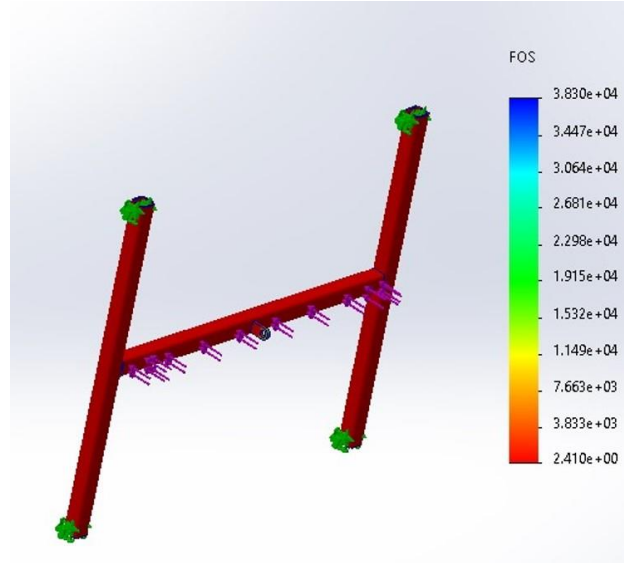

**Figure 5.8: Factor of safety for H link**

Figure 5.8 illustrates the factor of safety for the top bed frame of a nursing care bed. The figure shows the factor of safety (FOS) analysis for an "H" link in a bed under specific loading conditions using finite element analysis (FEA). The colour scale on the right ranges from 2.41 (red) to  $3.83 \times 10^4$  (blue), representing the FOS values across the structure. Areas in red indicate the lowest FOS, meaning these regions are closest to their failure limits under the applied loads. The blue areas indicate the highest FOS, suggesting these parts are farthest from their failure limits and are structurally secure. Purple arrows illustrate the applied loads, while green markers indicate the fixed supports or boundary conditions. The analysis shows that while the structure has regions with adequate safety margins (blue and green areas), the red zones may require reinforcement to ensure structural integrity and reliability under expected loading conditions.

### 5.2.3 Force Analysis of Base Frame

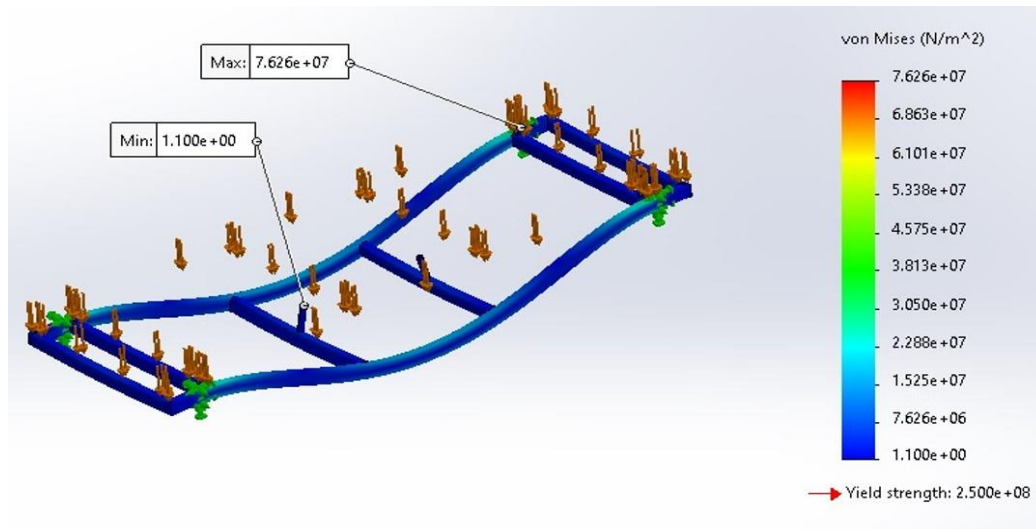

**Figure 5.9: Stress plot for Base Frame**

Figure 5.9 illustrates the von Mises stress distribution on the base frame of a nursing care bed. The stress plot for the bed base frame demonstrated the von Mises stress distribution under operational loads. The maximum stress value recorded was  $7.626 \times 10^7 \text{ N/m}^2$ , which is considerably lower than the yield strength of the material,  $2.5 \times 10^8 \text{ N/m}^2$ . This indicated that the base frame was structurally sound and could withstand the applied loads without risk of yielding. The high-stress areas, indicated by red on the colour scale, are located around the regions where the loads are applied, as shown by the orange arrows. These areas are critical and should be reinforced to ensure long-term durability and reliability. The minimum stress value of  $1.10 \times 10 \text{ N/m}^2$ , was shown in dark blue and represented regions with minimal stress, indicating low structural demands in those areas. Overall, the stress analysis confirms that the design of the bed base frame is safe and robust under the given loading conditions. However, it also highlights the importance of

reinforcing high-stress zones to enhance the overall safety and longevity of the bed's structural integrity.

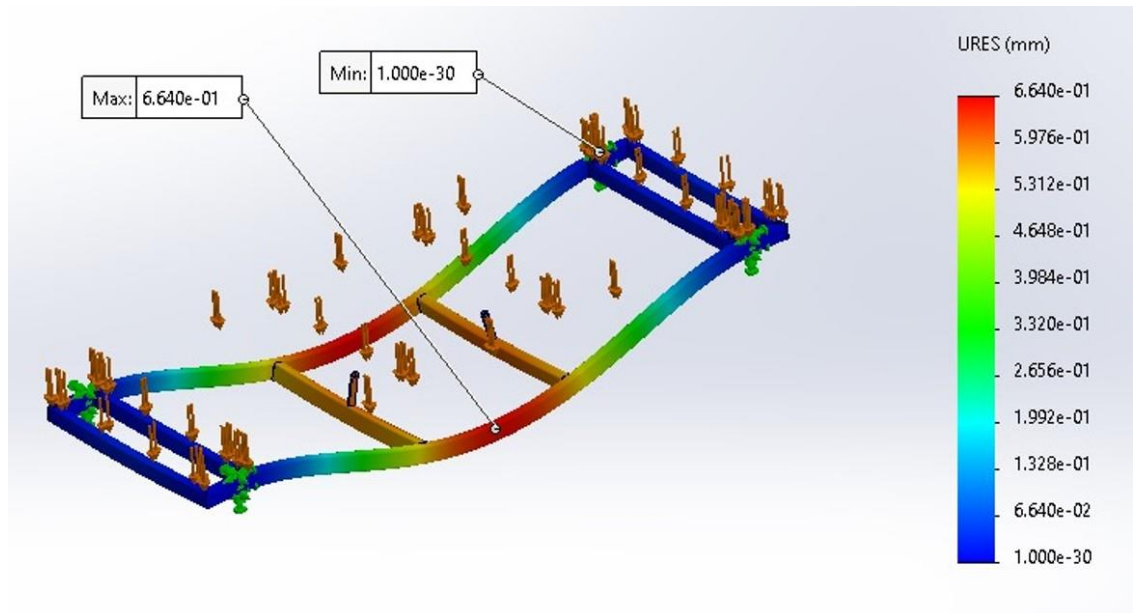

**Figure 5.10: Displacement plot for bed base frame**

Figure 5.10 illustrates the displacement distribution on the base, using a finite element analysis (FEA) result depicting the displacement of the bed base frame under applied loads. The colour scale on the right indicates the displacement magnitude in millimeters, ranging from a minimum value close to zero ( $1 \times 10^{-30}$ ) mm to a maximum value of approximately 0.6640 mm. The frame is colour-coded to show varying displacement levels, with the highest displacement regions marked in red and the lowest in blue. Orange arrows indicate the direction and points of applied loads, while green markers signify fixed supports or boundary conditions. The maximum displacement occurs at the centre of the frame, suggesting this area is the most flexible under load, whereas the ends, where

the supports are located, show minimal displacement. This analysis helps identify areas of the frame that may need reinforcement to ensure stability and durability during use.

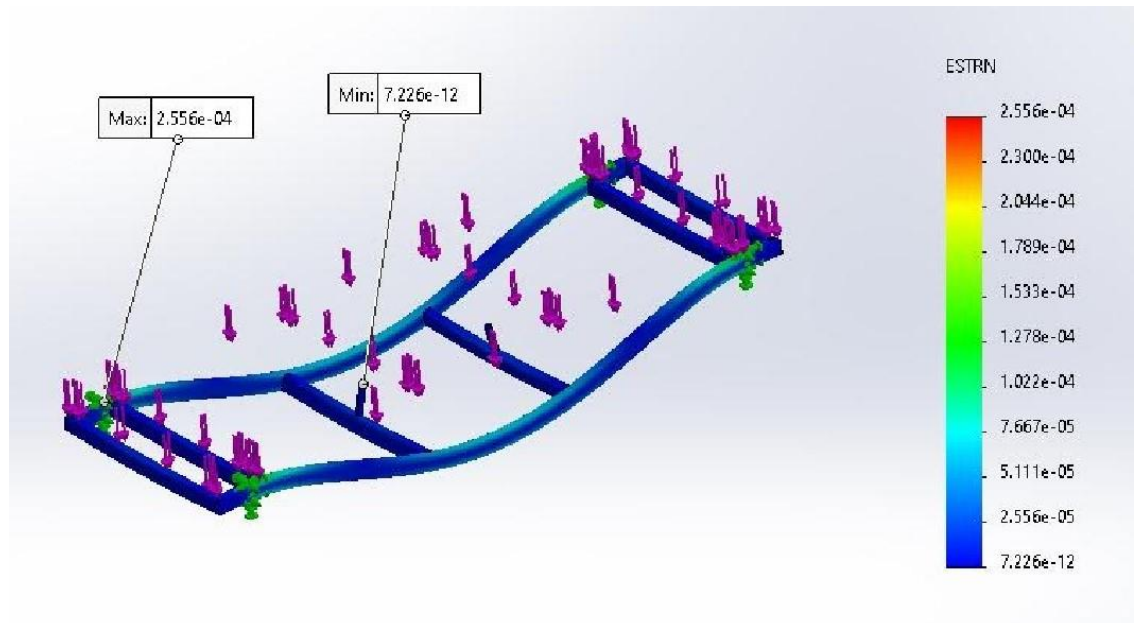

**Figure 5. 11: Strain plot for bed base frame**

The strain plot for the bed base frame in figure 5.11 illustrates the distribution of strain across the structure under load. The maximum strain value indicated is approximately  $2.556 \times 10^{-4}$ , while the minimum is  $7.226 \times 10^{-12}$ . This gradient of strain is visualized using a color scale, where regions exhibiting higher strain are marked in purple, indicating areas of greater deformation or stress concentration. The blue regions show lower strain values, suggesting they are experiencing less deformation. The arrows in the plot indicate the direction of strain, providing insight into how the structure is behaving under applied forces. This information is crucial for assessing the structural integrity and ensuring that the design can withstand operational loads without failure.

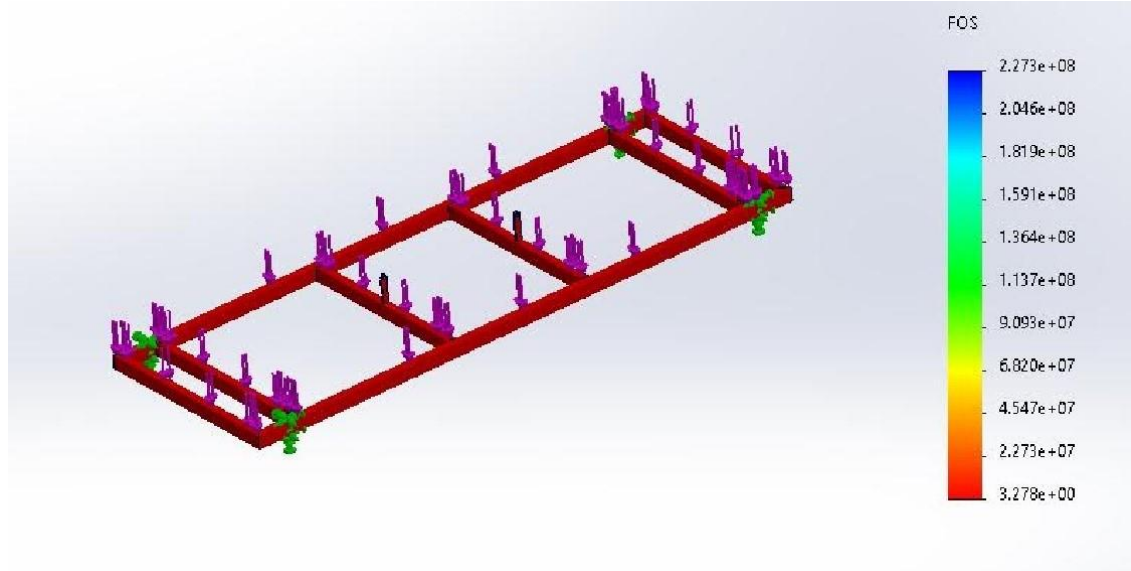

**Figure 5. 12: Factor of safety for base frame**

Figure 5.12 illustrates the factor of safety (FOS) distribution for a hospital bed base frame under specific loading conditions using finite element analysis (FEA). The colour scale on the right ranges from 3.278 (red) to 2.273 (blue), indicating the FOS values across the frame. Regions shown in red have the lowest FOS, suggesting these areas are closer to their failure limits under the applied loads, while regions in blue indicate the highest FOS, where the structure is most secure. Purple arrows represent the applied loads, and green markers denote the fixed supports or boundary conditions. The frame's overall design appears to have sufficient safety margins, especially in areas highlighted in blue and green. However, the red zones indicate potential areas for reinforcement to ensure the frame's reliability and durability under maximum expected loads.

## 5.2.4 Summary of Force Analysis Results

**Table 5. 7: Summary of Force Analysis Results**

<b>Design Parameter</b>	<b>Top Bed Frame</b>	<b>H Bed Link</b>	<b>Bed base Frame</b>
Stress (Max)N/m <sup>2</sup>	$9.416 \times 10^7$	$1.07 \times 10^8$	$7.626 \times 10^7$
Stress (Min)N/m <sup>2</sup>	$6.117 \times 10^1$	$6.527 \times 10^3$	1.10
Displacement (Max)mm	0.7922	0.4222	0.6640
Displacement (Min)mm	$1.00 \times 10^{-30}$	$1.00 \times 10^{-30}$	$1.00 \times 10^{-30}$
Strain (Max)	$2.482 \times 10^{-4}$	$2.724 \times 10^{-8}$	$2.556 \times 10^{-4}$
Strain (Min)	$2.759 \times 10^{-10}$	$2.627 \times 10^{-4}$	$7.226 \times 10^{-12}$
Factor of safety	2.655	2.41	2.273

## **CHAPTER SIX:SUMMARY, CONCLUSIONS, AND RECOMMENDATIONS**

### **6.1 Summary**

The design and simulation of the nursing care bed revealed some alignment and differed in some areas. Alignment areas were observed in the universal emphasis on ergonomic comfort, user-friendly controls, and safety compliance, to enhance patient care and healthcare provider efficiency. Common tools like Solid Works software are widely used for modelling and structural analysis, highlighting a unified approach in the engineering process. The difference arose from the choice of actuators, materials, and specific control systems, influenced by varying regional regulations, cost considerations, and specific patient needs. Additionally, while some designs integrate advanced automated features for smart functionality, others focus on basic modularity for easy customization and maintenance, reflecting differing priorities and technological capabilities across different healthcare environments.

### **6.2 Conclusion**

The study on designing and simulating a nursing care bed successfully achieved its objectives. The sizing and selection of suitable materials for the mechanical parts were precisely carried out, ensuring that the components meet the required strength, durability, and safety standards. The development of an automated actuating system has been implemented, demonstrating reliable and efficient motion control to enhance patient comfort and ease of use. The final phase involved a comprehensive simulation of the Nursing care bed parts, confirming the bed's performance under various operating conditions and patient scenarios. The results indicate that the design is robust, user-

friendly, and capable of significantly improving patient care and operational efficiency in healthcare settings.

### **6.3 Recommendations**

Based on the findings, it is recommended that further refinement of the material selection process be undertaken to explore advanced composite materials that may offer superior performance and weight savings. Additionally, integrating more sophisticated control systems, such as adaptive and predictive algorithms, could enhance the responsiveness and functionality of the actuated system. Regular maintenance protocols should be established to ensure the longevity and reliability of the nursing care bed. Moreover, constructing the bed and conducting real-world trials in hospital environments will provide valuable feedback for iterative improvements and ensure the design meets the practical needs of healthcare providers and patients.

### **6.4 Suggestions for Future Studies**

Future studies could focus on several areas to build upon the current research. Firstly, exploring energy-efficient motor systems and renewable power sources, such as solar or battery storage, could make the beds more sustainable and reduce operational costs. Finally, expanding the scope to include customizable features and modular designs could cater to a wider range of patient needs and preferences, making nursing beds more versatile and adaptable to various medical conditions and treatment environments.

## REFERENCES

- Adenwela, N. (2023). *Rack and pinion working Application pros and cons*. Retrieved from <https://dizz.com/rack-and-pinion-working-application-pros-cons-pdf/>
- Anjith.(2023).Double acting hydraulic actuator. Retrieved from <https://skill-lync.com/student-projects/project-1-14606>
- Ariyarit, A., & Kittipichai, R. (2012). The optimization design of hospital bed structure for independently separating left and or right leg using genetic algorithms. *Appl. Mech. Mater.*, 110-116(October), 4276–4283. doi: 10.4028/www.scientific.net/AMM.110116.4276
- Bajaj. (2024). *Icu bed meaning, types ,benefits ,prices and buying guide at financing options*. Retrieved from Intensive Care Unit (ICU) hospital beds are comfortable and easy to use, this is why they are frequently recommended for patients with multiple illnesses that require a change in posture
- Baker, S.(2023). *What You Need to Know About Trendelenburg and Anti-Trendelenburg Positions*.Retrieved from <https://www.bakare.co.uk/what-you-need-to-know-about-trendelenburg-and-anti-trendele>
- Best Metal Products. (2020). Telescopic hydraulic cylinder. Retrieved from <https://www.bestmetalproducts.com/telescopic-hydraulic-cylinders-and-their-advantage>

Biolab.(2024). Electric hospital beds. Retrieved from <https://biolabscientific.com/catalog/cs/4004/Electric-Hospital-Bed-Catalog-Biolab.pdf>

Bohman, E. (2017). Understanding Buckling Strength of Hydraulic Cylinders. Retrieved from <https://encyclopedia.pub/entry/8168>

Chiaravalloti, F., Gross, L., Rieder, K. H., Stojkovic, S. M., Gourdon, A., Joachim, C., & Moresco, F. (2007). A rack-and-pinion device at the molecular scale. *Nat. Mater.*, 6(1), 30–33. doi: 10.1038/nmat1802

Dhaware, Y., Palkuntwar, P., Narkhede, H., Meher, R., Chavan, P., & Gandevia, B. (2019). Review on Comparative Analysis of Ball Screw & Lead Screw. (June), 769–772.

Drayi, F. Y. A. (2019). The Impact of Hospital Bed and Beddings on Patients: The Ghanaian Healthcare Consumer Perspectives. *Int. J. Innov. Res. Adv. Stud.*, 6(1), 138–145.

Duarte, D. S., & Naveiro, R. M. (2020). Proposal of an alternative concept of the manually adjustable hospital bed for user experience improvement. *Prod. Manag. Dev.*, 18(2), 122–135. doi: 10.4322/pmd.2020.032

Energy. (2021). Hydraulic cylinder failure common causes. Retrieved from <https://energynow.com/2021/05/hydraulic-cylinder-failure-7-common-causes/>

- Expert. (2024). *Introduction to semi electric hospital beds*. Retrieved from <https://sdexpmedical.com/5-clarifications-on-semi-electric-hospital-bed/>
- Extruder. (2024). *Gear and worm gear understanding their function and manufacturing*. Retrieved from <https://extrudergearbox.net/worm-gears-understanding-their-function-and-manufacturing>
- Fazzino. (1995). hospital and medical equipment. Retrieved from [//c/Users/hp/Downloads/Fazzino Section1 Hospital and medical equipment-1.pdf](http://c/Users/hp/Downloads/Fazzino%20Section1%20Hospital%20and%20medical%20equipment-1.pdf)
- Finlay, J. (2007). Working Paper *Series The Role of Health in Economic Development*. (21).
- Forrellat Barrios, M. (2014). Calidad en los servicios de salud: Un reto ineludible. *Rev. Cuba. Hematol. Inmunol. y Hemoter.*, 30(2), 179–183.
- Gherssi, I., Marinño, M., & Miralles, M. T. (2018). Smart medical beds in patient-care environments of the twenty-first century: a state-of-art survey. *BMC Med. Inform. Decis. Mak.*, 18(1), 1–12. doi: 10.1186/s12911-018-0643-5
- Hankun. (2022). *Advantages and Disadvantage of pneumatic Actuators*. Retrieved from <https://www.hankunfluid.com/article/88/45.html>
- Hannifin, P. (2020). Compact EHA *Electro-Hydraulic Actuators for high power density applications*. Retrieved from <https://www.parker.com/content/dam/Parker-com/Literature/Hydraulic-Pump-Division/Oild>

- Hashim, W. M., Al-Salihi, H. A., & Al Zubaidi, F. N. (2022). Effects of temperature on the properties of HL32 oil in the conventional hydraulic actuators. *Heliyon*, 8(12), e11831. Retrieved from <https://doi.org/10.1016/j.heliyon.2022.e11831> doi: 10.1016/j.heliyon.2022.e11831
- Hiwin. (2024). *Internal Recirculating type ball screw*. Retrieved from <https://www.hiwin.tw/products/ballscrew/internal.aspx>
- Hydro, S. (2024). *Advantages and application of telescopic hydraulic cylinders*. Retrieved from the key benefit of these cylinders is their ability to be used efficiently in limited-space areas. While extending or retracting, they can be set up so that every moving stage extends at the same duration, maintaining a steady force and spe
- Industry, s. G. (2020). *Customizable Hospital Bed Hydraulic Cylinder for OEM and ODM Solutions*. Retrieved from <https://www.made-in-china.com/?pv id=1i7b4ard6423&faw id=1i7b4igvt170>
- Javed, S. A., Liu, S., Mahmoudi, A., & Nawaz, M. (2019). Patients' satisfaction and public and private sectors' health care service quality in Pakistan: Application of grey decision analysis approaches. *Int. J. Health Plann. Manage.*, 34(1), e168–e182. doi: 10.1002/hpm.2629
- Jill Seladi-Schulman. (2021). *What are the benefits of elevating your legs*. Retrieved from <https://www.healthline.com/health/elevating-legs>

John Fenske. (2023). *Electric linear Actuators Explained frequently asked questions and answers*. Retrieved from <https://www.tolomatic.com/blog/how-does-a-linear-actuator-work/>

John Rowse. (2024). *Pneumatic vs Electrical Actuator*. Retrieved from <https://www.rowse-pneumatics.co.uk/blog/post/pneumatic-vs-electrical-actuators?srslt>

Laokri, S., Soelaeman, R., & Hotchkiss, D. R. (2018). Assessing out-of-pocket expenditures for primary health care: How responsive is the Democratic Republic of Congo health system to providing financial risk protection? *BMC Health Serv. Res.*, 18(1), 1–19. doi: 10.1186/s12913-018-3211-x

Lewis, K. (2022). Telescopic hydraulic cylinder 5 key benefits. Retrieved from <https://cylindersinc.com/blog/telescopic-hydraulic-cylinders-key-benefits>

Lewis, K. (2024). An essential *guide* to hydraulic cylinder preventive maintenance. Retrieved from Although hydraulic cylinders are durable equipment, their optimal operation necessitates regular maintenance. Since the rod and piston seals are the primary components that contain pressure, it is imperative to maintain their integrity

Link. (2024). What is an actuator. Retrieved from <https://www.linak.com/products/linear-actuators/what-is-an-actuator>

- Lloyd Leugner. (2024). *Hydraulic system leakage. The Destructive drip*. Retrieved from <https://www.machinerylubrication.com/Read/21/hydraulic-system-leakage>
- Mathieu, J. L. (2016). *Reverse trendelen burg position*. Retrieved from Post-Trendelenburg position
- Medik. (2022). *Automatic Hospital bed*. Retrieved from <https://www.medik-medical.com/data/upload/20220701/62be64bfbe4c0.pdf>
- Nazaria. (2023). *Types of hospital beds*. Retrieved from <https://www.gilaniengineering.com.au/types-of-hospital-beds/>
- Nikamel. (2024). *what is the difference between Semi Electric and Full Electric hospital bed*. Retrieved from <https://www.nilkamaledge.com/blogs/inspirations/whats-the-difference-between-semi-el>
- Onkar, A., & Furnitech, O. (2014). DESIGN AND FABRICATION OF BED FOR Dr A . B . ANDHARE Department of Mechanical Engineering Visvesvaraya National Institute of Technology, (August).
- Parker. (2015). *pnuematic cylinder*. Retrieved from [https://www.parker.com/literature/Pneumatics Division Europe/PDE-documents/Pneumatic Cylinder - P1D ISO Series – Catalogue DE2570TCUK.pdf](https://www.parker.com/literature/Pneumatics%20Division%20Europe/PDE-documents/Pneumatic%20Cylinder%20-%20P1D%20ISO%20Series%20-%20Catalogue%20DE2570TCUK.pdf)
- Portea. (2022). *Hospital beds and thier types*. Retrieved from <https://www.portea.com/medical-equipment/hospital-beds-and-types/>

- Premium. (2024). *Understanding worm gears: A Detailed exploration*. Retrieved from <https://premium-transmission.com/blog/understanding-worm-gears-a-detailed-exploratio>
- Price, S. (2022). types of actuators. Retrieved from <https://control.com/technical-articles/mechanical-motion-fluid-vs-electric-actuators>
- Pugin, K. G. (2020). Improving the reliability of hydraulic systems of technological machines. *IOP Conf. Ser. Mater. Sci. Eng.*, 971(5). doi: 10.1088/1757-899X/971/5/052042
- Pyramid. (2024). *Advantages of electric actuators over hydraulic systems*. Retrieved from <https://www.pyramideng.com/News/View-Article/ArticleId/6/Advantages-of-Electric-Actu>
- Rao, R. (2023). *What is an Actuator? Types. principal and Application*. Retrieved from <https://www.wevolver.com/article/what-is-an-actuator-principles-classification-and-a>
- Raversbergen, N. (2020). Types of electric linear actuator. Retrieved from <https://www.firgelliauto.com/blogs/actuators/types-of-electric-linear-actuators>
- Rich, K. (2019). Trendelenburg position in hypovolemic shock: A review. *J. Vasc. Nurs.*, 37(1), 71–73. Retrieved from <https://doi.org/10.1016/j.jvn.2019.01.002> doi: 10.1016/j.jvn.2019.01.002

- Ruben, E. (2023). Electric *actuator* types and uses. Retrieved from Electric actuators work based on the principle of converting electrical energy into mechanical motion.
- Ryan King. (2020). *Hydraulic Vs Pneumatic*. Retrieved from <https://www.rowse.co.uk/blog/post/hydraulics-vs-pneumatics>
- Sendath, K. (2024). *Hydraulic Vs Pneumatics Vs Electric Actuators*. Retrieved from <https://yorkpmh.com/resources/hydraulic-vs-pneumatic-vs-electric-actuators/>
- Shanghai. (2024). *Pneumatic Electric Actuators*. Retrieved from <https://valves-actuator.com/pneumatic-actuators-advantages/>
- Shrikrishna, T. A. (2022). ‘ *Design and Manufacturing of Automatic Height Adjustable Stretcher* ’. (3), 3186–3190.
- Silar, J. (1980). Hydraulic cylinders. *Czech. Heavy Ind.*(7 , 1980), 39–46.  
doi: 10.1016/b978075066276-5/50005-x
- Singh Bisht, M. (2020). *Nipah Virus Infection: A New Challenge for Health Care Services and Health Care Personnel* (No. October). Retrieved from [www.rfppl.co.in](http://www.rfppl.co.in) doi: 10.21088/ijsn.2277.467X.8319.4
- SKF. (2018). *High performance actuator catalogue*. Retrieved from [https://lmotion.ru/cataloguespdf/high performance \\_actuator v2.pdf](https://lmotion.ru/cataloguespdf/high_performance_actuator_v2.pdf)

- Tang, J. (2024). *Why electric actuators are better than pneumatic actuators for packaging Machinery*. Retrieved from [https://blog.orientalmotor.com/why-electric-actuators-are-better-than-pneumatic-actu](https://blog.orientalmotor.com/why-electric-actuators-are-better-than-pneumatic-actuators)
- Thomson. (2007). *Lead screws*. Retrieved from [https://www.thomsonlinear.com/downloads/screws/neff leadscrews\\_bruk.pdf](https://www.thomsonlinear.com/downloads/screws/neff%20leadscrews_bruk.pdf)
- Timotion. (2023). *0 Reasons To Choose Electric Linear Actuators*. Retrieved from 0 Reasons To Choose Electric *Linear* Actuators
- Uzny, S., & Kutrowski, L. (2019). Strength Analysis of a Telescopic Hydraulic Cylinder Elastically Mounted on Both Ends. *J. Appl. Math. Comput. Mech.*, 18(1), 89–96. doi: 10.17512/jamcm.2019.1.08
- Water Orthopedics. (2024). *Electric and Manual beds*. Retrieved from <https://waterorthopedics.com/hospital-beds-manual-hospital-beds-electric-hospital-be>
- Weinger. (2010). *Hand book of human factors in medical device*. Retrieved from [https://books.google.co.uk/books?hl=en&lr=&id=jAemLm2zu\\_oC&oi=fnd&pg=PP1&ots=NR9k16a](https://books.google.co.uk/books?hl=en&lr=&id=jAemLm2zu_oC&oi=fnd&pg=PP1&ots=NR9k16a)

Werner, M. (2024). *9 benefits of sleeping with your head elevated*. Retrieved from <https://www.ghostbed.com/pages/9-benefits-of-sleeping-elevated?srsltid=AfmBOoqIz2lTD>

Xedus. (2024). *The pink reverseT Kit*. Retrieved from <https://xodusmedical.com/PinkReverse>

Zhang, Y., Zhou, C., & Feng, H. (2023). An efficiency calculation model for ball screws by accounting for lead errors. *Math. Model. Eng.*, 9(4), 188–197. doi: 10.21595/mme.2023.23735

Zhygear. (2023). *Rack and Pinion Gears in Linear Actuators: Powering Dynamic Motion Control*. Retrieved from <https://www.zhygear.com/rack-and-pinion-gears-in-linear-actuators-powering-dynamic-m>

## APPENDICES

### Appendix A: Drawings

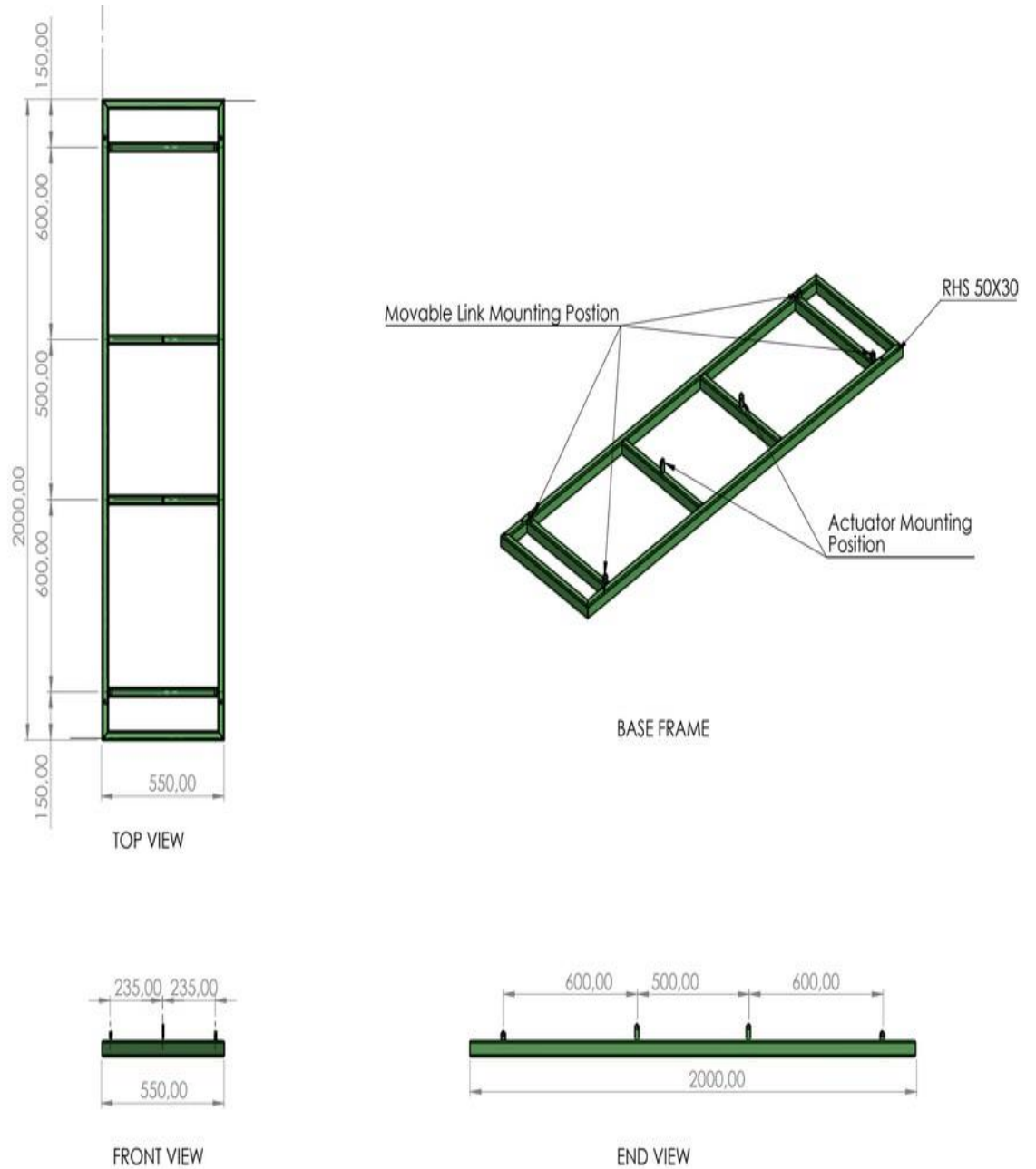

**Figure A.1:** Base Bed Frame Engineering Drawings

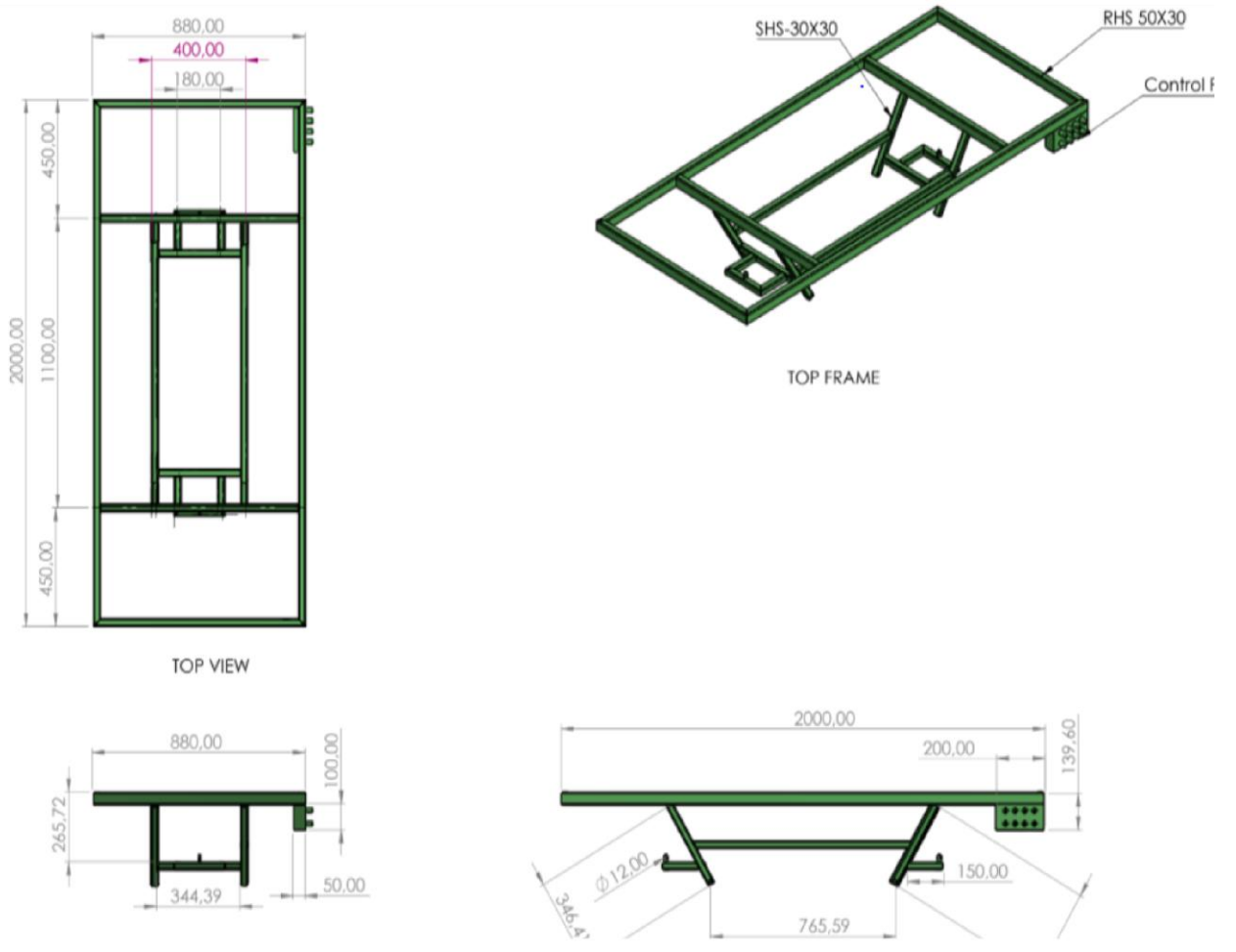

**Figure A.2:** Engineering drawings for top frame

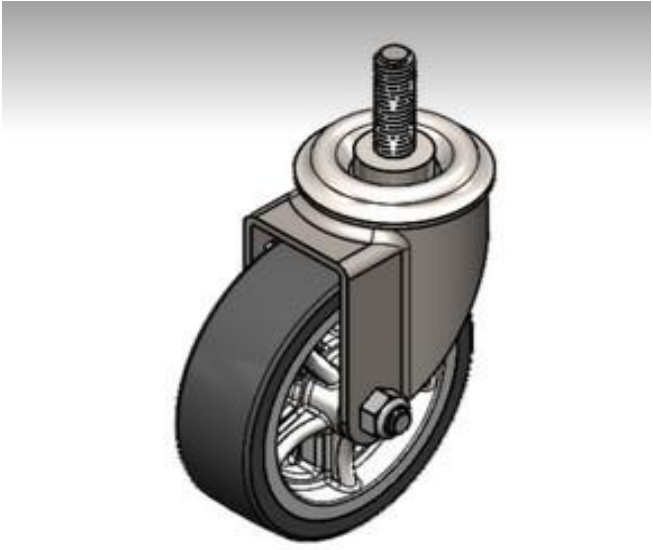

Caster wheel with Brake system

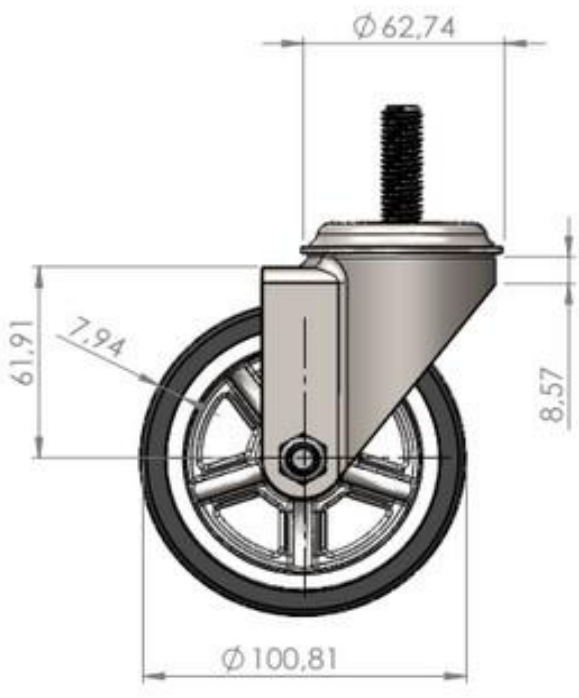

Figure A.3: Caster wheel Engineering Drawings

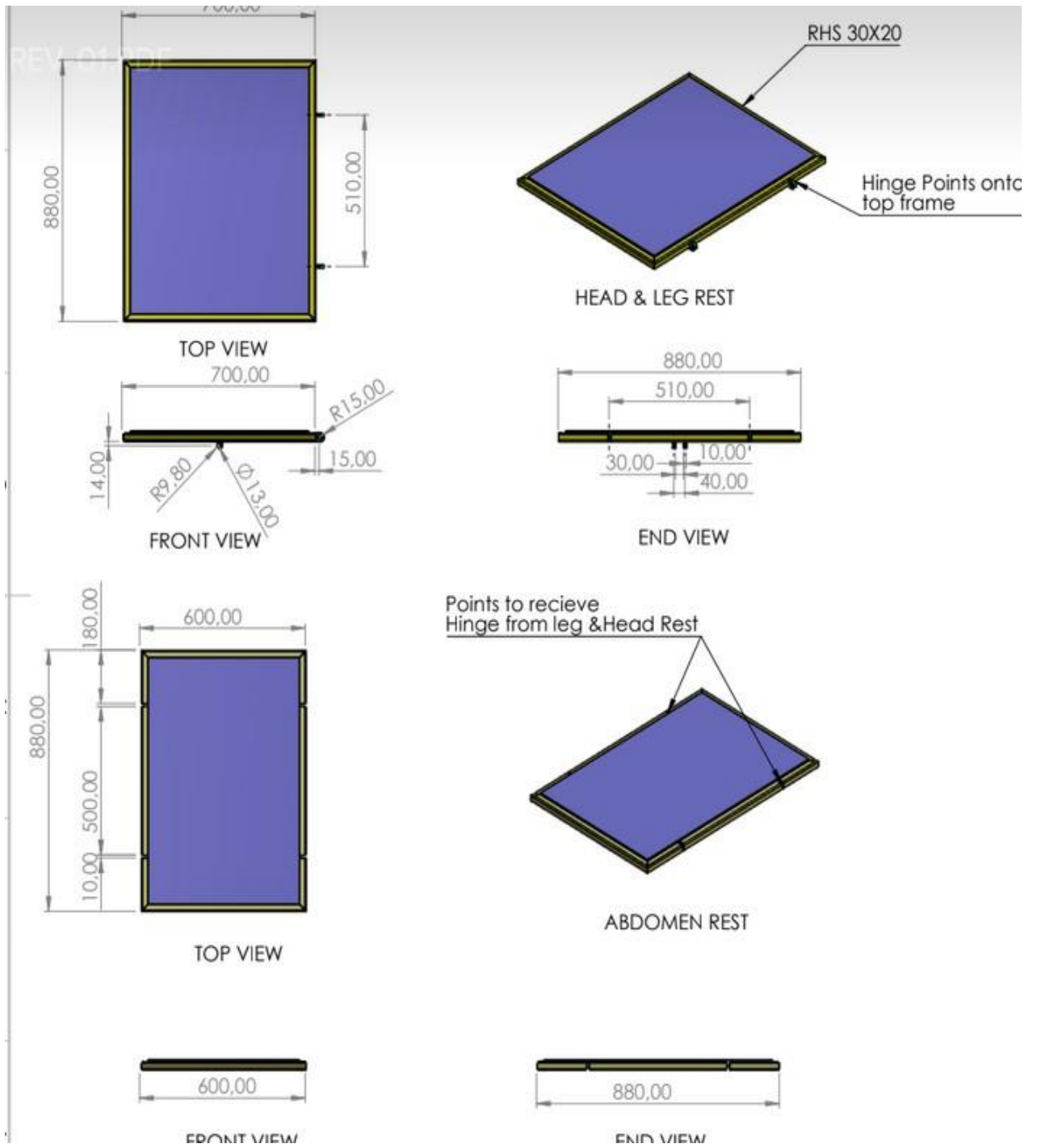

Figure A.4: legs, Head and Abdomen bed segment Engineering Drawing for Nursing Care Bed